



Unviersty of Anbar



Shear Strength of Directly and Indirectly Loaded Rectangular Self-Compacted Reinforced Concrete Deep Beams Containing Recycled Concrete as Coarse Aggregate

Thamer Hussein Amer Alhussein ^a, Jamal Abdul Samad Khudhair

^a Department of Civil Engineering, College of Engineering, University of Basrah, Al-Basrah, 61004, Iraq

^b Department of Civil Engineering, College of Engineering, University of Basrah, Al-Basrah, 61004, Iraq

PAPER INFO

Paper history:

Received 20/7/2020

Received in revised form

25/8/2020

Accepted 2/9/2020

Keywords:

Rectangular Deep Beam, Shear Strength, Directly and Indirectly Loaded, and Recycled Concrete Aggregate Self-Compacted Concrete (RCASCC)

ABSTRACT

Deep beams with rectangular cross-sections are widely used in concrete structures. In the present study, reinforced concrete rectangular deep beams cast with self-compacted concrete (SCC) which contains recycled concrete as coarse aggregate (RCA) were tested under directly and indirectly loading conditions. In the experimental work, fifteen deep beams were investigated, the first parameter considered in this study was the shear span to effective depth (a/d) ratio. The other variable is the replacement ratio by which the normal coarse aggregate is replaced by RCA. The beams were cast without the use of shear reinforcement. During the tests, the response of the beams including the cracking load, the ultimate load, concrete strain, and mid-span deflection were recorded. Test results indicate that the presence of RCA caused a reduction in the values of cracking and ultimate loads. For instance, the cracking load was reduced by 9%, 23%, and 50% and the ultimate load was reduced by 2%, 23%, and 25% as RCA replacement increased by 25%, 50%, and 75% respectively for a/d ratio equals 1.0. Further, by increasing the a/d ratio, the ultimate load was decreased due to the lower contribution of arch action shear transfer in the beam with a higher (a/d) ratio.

© 2014 Published by Anbar University Press. All rights reserved.

1. Introduction

Demolition of buildings, roads, and bridges that have reached the end of their lifespan results in tremendous amounts of waste worldwide, and such wastes have negatively impacted the environment. To reduce further wasting of such materials and minimize the use of natural resources, a convenient solution would be using these waste materials for the manufacturing of structural concrete, as partial replacement of natural aggregate. The recycled concrete aggregate (RCA) has been effectively used by many research studies in the literature by partially replacing the normal aggregate [1-3]. Self-compacted concrete (SCC) is an important innovation in

concrete technology. The SCC workability characteristic allows concrete to fill molds even in densely reinforced elements with no segregation solely under its weight and eliminates the compaction efforts [4,5]. Reinforced concrete beams are commonly classified as deep and shallow beams. The deep beam is a structural element that loaded on one face and supported on the other face so that compression struts can evolve between the loads and the supports [6]. According to ACI code 318-19, a beam is considered as a deep beam when satisfies either its clear span does not exceed four times the overall member depth or the applied concentrated load presents within a distance of two times the member depth from the face of the support [6]. As a result,

* Corresponding author: Thamer Hussein Amer Alhussein ; enthamer@gmail.com ; +9647503451298

the distribution of strain is no longer considered linear so it is well known that the classical elastic theory of bending is not appropriate to such problems as deep beams and shear deformations of such beam become important in comparison with pure flexure. The significance of this study is represented by the employment of the deep beam which has a very important application in the field of engineering construction, and by using the recycled concrete as a partial replacement of normal aggregate which has an important environmental impact and finally by utilizing the self-compacted concrete technique which reduces the construction efforts.

2. Loading of Simply Supported Deep Beams

Simply supported deep beams can be classified according to loading conditions into directly loaded deep beams (DLDB) and indirectly loaded deep beams (ILDB) as shown in Figure 1 [7]. In the DLDB, the applied forces are acting on the top or compression face of the beam and reactions are acted underside the face of the beam. While in the ILDB, the loads are applied via shear to the sides of the members [8]. The indirectly loaded rectangular deep beams have lower shear strength than the directly loaded deep rectangular beams due to the lower effect of the tied arch action in the indirectly loaded rectangular deep beams [9]. To improve the ultimate load capacity of the ILDB, Paul [10] concludes that a sufficient hanger or suspension reinforcement at the position of the load application and a good anchoring in the compression zone should be provided.

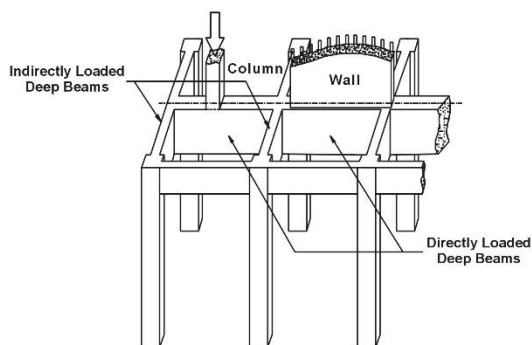

Figure 1: Directly and indirectly loaded beams

3. Experimental program

The experimental work was carried out in the laboratory of civil engineering, University of Basrah.

3.1. Materials. The properties of the materials used in the preparation of the tested reinforced SCC R-beams with RCA are described below.

• Cement

Ordinary Portland cement (type I) was used in this study. This cement complies with the Iraqi specification number (5/1984) [11].

• Water

Potable water was used for both mixes and curing the concrete samples.

• Fine Aggregate

Normal sand from the Al-Zubair region in Basra city was employed. The fine aggregate was satisfied with the Iraqi Specification No.45/1984 Zone 2 [12].

• Coarse Aggregate

Crushed gravel from the Al-Zubair region in Basra city with a maximum size of 20 mm was utilized. The coarse aggregate grading is within the requirements of Iraqi Specification No. 45/ 1984 [12].

• Recycled Concrete Aggregate (RCA)

Recycled concrete aggregate which was used in this study was obtained from the destruction of concrete waste materials. The RCA grading is within the requirements of Iraqi Specification No. 45/1984 [12]. The maximum size, of this aggregate, was 20mm.

• Superplasticizer (SP)

A high range of water reducers must be used to produce the SCC, especially with low water to cement ratios. In this work, the superplasticizer used is known commercially as "GLENIUM51". It is a new generation of modified POLYCARBOXYLIC. It is compatible with the Portland types of cement used in this study, free from chlorides, and meets the ASTM C494 [13]. SP concrete exhibits a large increase in the slump without the occurrence of segregation. The other advantage of SP is the deletion in the initial setting time which allows extra time for casting and finishing the concrete surface. SP has been used and recommended by past research studies [2,3].

• Steel Reinforcement

The steel reinforcements are deformed bars with diameters of 16, 12 and 10mm was used for both longitudinal reinforcement and stirrups. Three tensile specimens of each bar size were tested in the lab. Test results indicate that the bars comply with the ASTM A615/A615M-04b [14]. Table 1 shows the averaged test results for each size. if figure or graphs

are duplicated from other reference, a citation should be appearing at the end of caption.

Table 1 Properties of Reinforcing Bars

Bar size (mm)	Test results		
	Yield stress (N/mm ²)	Ultimate Strength (N/mm ²)	Elongation (%)
10	482	595	12
12	516	647	13
16	530	677	12

4. Design of Concrete Mixes

Self-compacted concrete is largely affected by the characteristics of materials and the mix proportions. Several trial concrete mixes were prepared to obtain two types of self-compacting concrete, the first with natural coarse aggregate and the second with recycled concrete aggregate as a partial replacement of natural coarse aggregate. The replacements were (0%, 25%, 50% and 75%). Tables (2, 3, and 4) show the mix designation, amount of used mix materials and hardened RCASCC properties.

Table 2 Mix Designation

Mix Designation	Description
SCC-RCA 0%	SCC without Recycled Concrete Aggregate.
SCC-RCA 25%	SCC with 25% of Recycled Concrete Aggregate.
SCC-RCA 50%	SCC with 50% of Recycled Concrete Aggregate.
SCC-RCA 75%	SCC with 75% of Recycled Concrete Aggregate.

Table 3 Concrete Mix Constituents for Control Mix (0% RCA)

RCA (%)	$f_{cu_{Avg.}}$ (MPa)	$f_c^{calculated}$ (MPa)	f_t (MPa)	EC (MPa)
0	42.2	33.8	3.96	27510
25	40.4	32.3	3.94	26950
50	36.6	29.5	3.43	25740
75	32.4	26.0	3.12	24110

5. Beams details

The experimental program consists of casting and testing fifteen directly and indirectly loaded rectangular reinforced concrete deep beams, cast with self-compacting concrete containing recycled concrete as coarse Aggregate. Three (a/d) ratios were con-

sidered as presented in Tables (5 and 6) and Figures (3 to 5)

Table (4) Properties of Hardened RASCC

Material	Content
Cement kg/m ³	379
Lime Stone Powder kg/m ³	162
Coarse Aggregate kg/m ³	944
Fine Aggregate kg/m ³	755
Water kg/m ³	167
SP kg/m ³	4

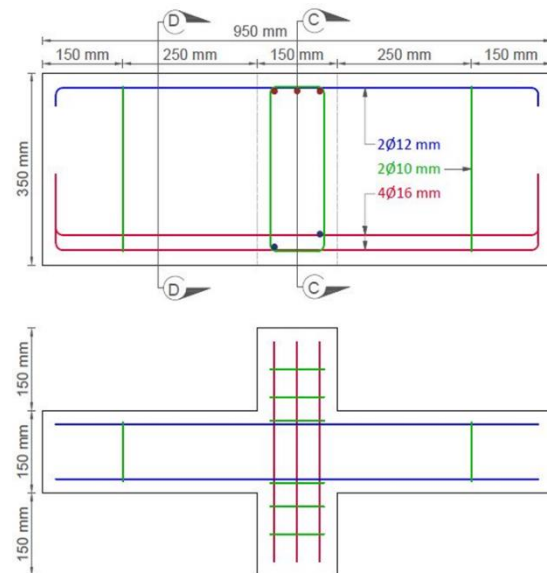

Figure 3: Indirectly Loaded Beam

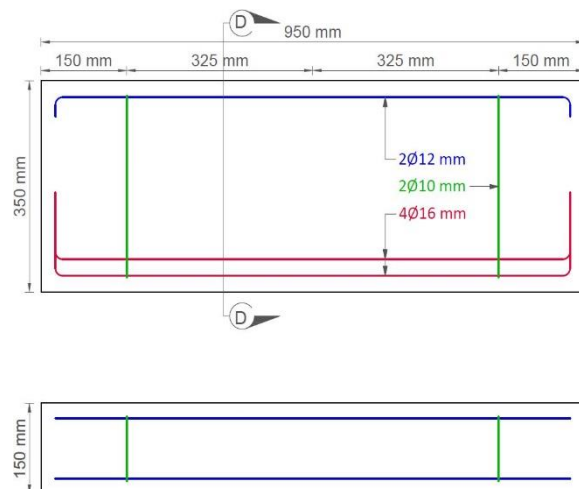

Figure 4: Directly Loaded Beam

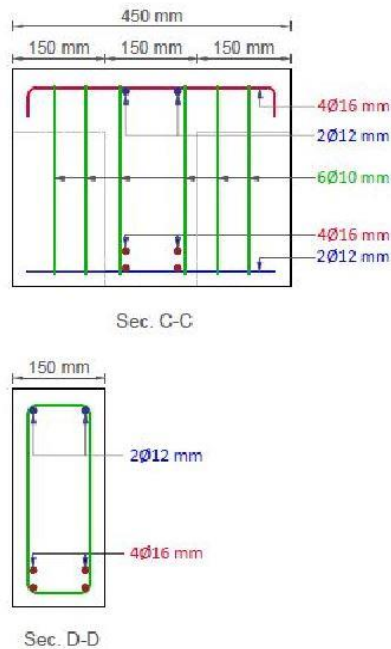

Figure 5: Cross Section of Beams

Table 5 Indirectly Loaded Beams

SN	a/d	RCA%			
		0	25	50	75
G1RB	1.0	0	25	50	75
G2RB	1.35				
G3RB	1.7				

Table 6 Directly Loaded Beams

SN	a/d	RCA%
DG1RB3	1.0	50
DG2RB3	1.35	
DG3RB3	1.7	

6. Mixing Procedure

The concrete mixture was prepared using a laboratory mixer with a capacity of 0.1 m³. A constant mixing procedure was considered and executed throughout this study to acquire the maximum efficiency of superplasticizer and full dispersion of the particles. This procedure can be summarized as follow: First, cement, limestone powder, and aggregate were mixed for 1 minute. Second, 80% of the mixing water as slowly added to the mixture and continue mixing for another minute. Third, the 20% left of mixing water with superplasticizer dissolved in it was slowly added while continue mixing for another minute. Forth, the mixing was continued for another three minutes. Fifth, the mixture was left to rest for

three and a half minutes. Finally, the mixture was re-mixed for a half minute and discharged for conducting fresh concrete tests and casting the specimens. A similar procedure was adopted by some research studies in the literature [15, 2].

7. Casting, Curing of Beams

An advantage of using the self-compacted concrete is eliminating the vibration efforts where the molds and forms were casted without any segregation. The forms and molds were oiled prior to placing the reinforcement cage and casting the concrete. The molds were restrained by a U-shape steel plate to prevent any movement due to the lateral pressure of fresh concrete. After the casting process was completed, leveling the top surface of the concrete was done by using a hand trowel. To prevent evaporating the water from the concrete, the specimens were covered by a nylon sheet. According to the ACI 318-19, the beams were moist cured for fourteen days under damp canvas and then stored in suitable laboratory conditions. The casting and curing procedures of these specimens are depicted in Figure 6.



Figure 6: Casting and Curing of RCASCC Beams.

8. Testing of Beams

Two days prior to conducting the tests, the specimens were painted to trace the cracks easily. The strain measurements were done using a 10 mm Aluminum discs with a central hole of 1.5 mm in diameter. The position of the discs was marked and placed using an epoxy resin. Figure 7 shows the typical arrangement and experimental setups. In the indirectly loaded RCASCC beams, a steel spreader beam was used to apply the two equal point loads. The steel spreader is seated on two roller supports which placed on top of the RCASCC beams. While in the directly loaded RCASCC beams, the steel spreader is setting on the roller at the midspan of the concrete beams. The Universal Testing Machine (UTM) with a capacity of 2000 kN was employed to apply the load. Two mechanical dial gages were used to measure the midspan deflection within an accuracy of (0.01 mm). Also, the crack width was measured by using a hand microscope. A test was terminated when the total load on the specimens started

to drop off. Figure 7 shows the testing setup for indirectly loaded RCASCC beams while Figure 8 illustrates the test configurations indirectly loaded RCASCC beams.

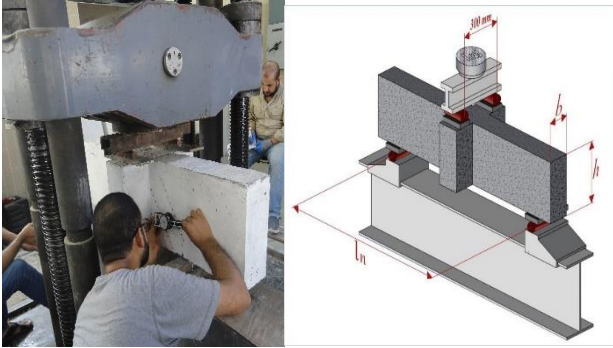

Figure 7: The Typical Arrangement and Experimental Setups of Indirectly Loaded Deep Beam.

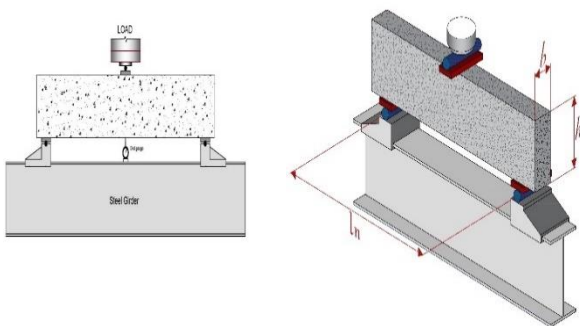

Figure 8: The Typical Arrangement and Setups of Directly Loaded Deep Beam.

9. Result and Discussion

The crack patterns of the three series of specimens showed that a significant part of the load is transferred to support through compression struts as shown in Figures (9 and 10). This load transfer mechanism induces a common type of failure in deep beams [16, 17]. It can be observed that when the load was increased, inclined cracks were developed in the shear span region. After internal forces were redistributed, the beams sustain the additional load through arch action. All of the tested beams fail in shear when the diagonal shear cracks widen. Nevertheless, and no local failure is observed due to the crushing of concrete under the load or over the supports. The main bars are provided with adequate end anchorage. Therefore, no anchorage failure is encountered during testing. At low load levels, all deep beams behaved elastically because they were free from cracking. With the increase of loading, a small flexure crack appeared at or near the midspan at the bottom of the beam, then it extended upward. With further load, an inclined crack appeared at shear

zone approximately at the mid-length of the load path. Thereafter, the main shear crack situated close to the mid-depth of beams at an angle of 35° to the horizontal axis started to appear. The angle is approximately equal to the angle of the line connecting, the applied load and the support. Increasing the load leads to a small increase in crack width and before failure, another inclined crack appeared parallel to the first one and then the shear crack extended toward the bottom and top edges of the beam, widened, and propagated up to failure in shear. All beams are without web reinforcement, the inclined crack extended towards top and bottom without an appreciable increase in crack width and failed in shear suddenly without a significant increase in crack width due to the absence of web reinforcement, especially for deep beams with small shear span to effective depth ratio (a/d).



Figure 9: Crack pattern for indirectly loaded beams



Figure 10: Crack pattern for directly loaded beams

10. Ultimate and Inclined Cracking Loads

The mechanical behavior of indirectly loaded deep beams differs from the directly loaded deep beams since the large portion of the additional strength associated with small shear span to effective depth ratios had been lost. Furthermore, shear strength and shear at the first diagonal tension crack are lower for indirectly loaded deep beams than those for directly loaded deep beams. This finding can be attributed to the lack of confining compressive forces in indirectly loaded deep beams. In the present study, twelve indirectly loaded deep RC beams without web reinforcement were subjected to two-point loads as shown in Figure 7. While three directly loaded deep RC beams without web reinforcement were subjected to one-point load applied at midspan as shown in Figure 8. The main variables are

the RCA replacement ratio and the (a/d) ratio. Test results are shown in Tables (7 and 8).

10.1 Effect RCA replacement ratio

The variation in the percentage of RCA ratios was significantly affecting the cracking and ultimate loads as shown in Table 7 and Figures (11 to 13). For a given (a/d) ratio, both cracking and ultimate loads decrease with the increase of RCA replacement ratio. The higher reduction in cracking and ultimate loads is due to the higher RCA content. This can be attributed to the lower compressive strength of concrete with the increase in the RCA replacement ratio. Beams with zero replacement of RCA exhibited higher ultimate load than RCA 25%, 50%, and 75% for the same (a/d) ratio. The reduction in the ultimate loads was represented by the difference between ultimate load with (25, 50, and 75%) RCA and Pult of zero RCA divided by Pult of zero RCA. Beams in the first group, G1RB1, G1RB2, G1RB3, and G1RB4 showed (0%, 2%, 23%, and 25%) reduction in the ultimate load respectively. While the reduction in beams of the second group, G2RB1, G2RB2, G2RB3, and G2RB4 were (0%, 8%, 5%, and 18%) respectively. Beams of the third group, G3RB1, G3RB2, G3RB3, and G3RB4 experienced a reduction of (0%, 9%, 13%, and 31%) respectively. The ratios of the inclined cracking load to the ultimate load for all beams were ranged from (22% to 47%) with an average value of (39%) and a standard deviation of (8%). The increase in replacement ratio of RCA caused a reduction in compressive strength, splitting tensile strength, and modulus of elasticity. This leads to a decrease in the values of cracking load and the ultimate load. It was seen that all beams carried additional load after diagonal loading.

10.2 Effect of (a/d) Ratio

The relative magnitude of shearing and flexural stresses is mainly affecting the inclined cracking and the failure of reinforced concrete deep beams [18]. This effect is represented as a function of (a/d) ratio. Stress distribution in the indirectly loaded beams after forming of inclined crack pointing out to a tendency towards the arch action. However, pure arch action was not reached because of the force in the tension reinforcement was not constant along the span [19]. From Table (7 and 8), it can be drawn that

the cracking and ultimate loads was increased by the reduction of (a/d) ratio. For rectangular indirectly loaded deep beams with a 50% RCA ratio, an increase of 55% and 79% respectively, is obtained by reducing (a/d) ratio from 1.7 to 1.0. Also, the increase was 21% and 39% respectively for the cracking and ultimate load with a reduction in (a/d) from 1.35 to 1.0. For directly loaded deep beams with RCA percentage of 50%, the cracking and ultimate loads were increased by 47% and 48% respectively by reducing (a/d) ratio from 1.7 to 1.0. Further, with a reduction of (a/d) ratio from 1.35 to 1.0, the ultimate load was increased by 21% and 31% respectively. This increase in cracking and ultimate load is due to the higher contribution of arch action shear transfer in beams with a lower (a/d) ratio. This phenomenon has been confirmed by other researchers in the literature [8].

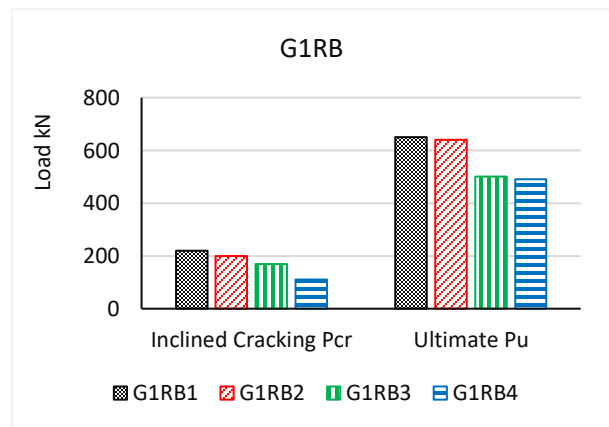

Figure 11: Ultimate and Cracking Load for First Group

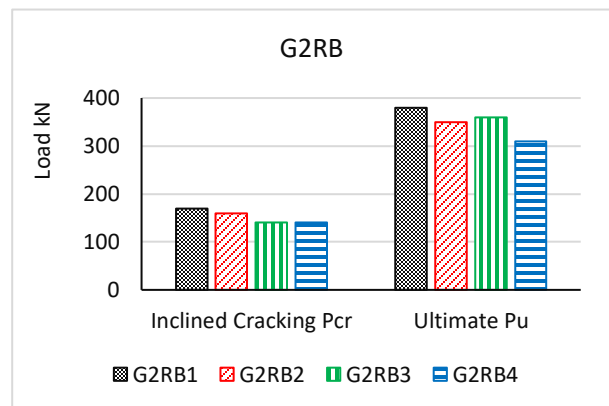

Figure 12: Ultimate and Cracking Load for Second Group

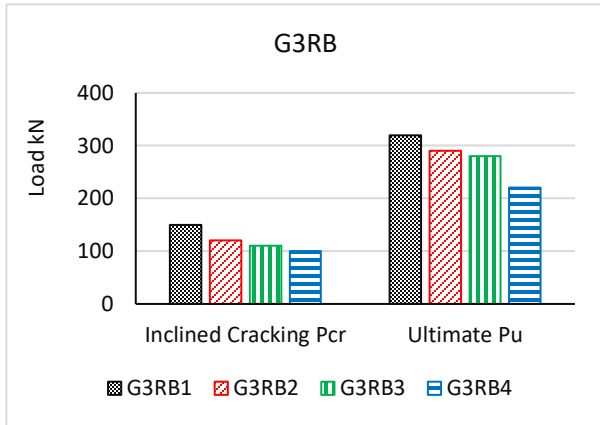

Figure 13: Ultimate and Cracking Load for Third Group

11. Reserved Capacity

The reserved strength of the tested deep beams is listed in Tables (7 and 8). The reserved strength of the beams is defined as the ratio of the difference be-

tween ultimate load and diagonal cracking load to diagonal cracking load expressed in terms of a percentage [20].

The indirectly loaded beams showed lower reserved strength than directly loaded beams with the same (a/d) ratio and RCA. It can be noticed that the reserved strength increased with the decrease of (a/d) ratio. This behavior is attributed to the higher contribution of arching action for the lower (a/d) ratio.

12. Deflection

From Figures. (14, 15, and 16) it can be observed that for a given (a/d) ratio the deflection increased with the increase in the RCA replacement ratio. This behavior is attributed to the lower modulus of elasticity of concrete with RCA.

Table 7: Inclined Cracking and Ultimate Load for Indirectly Loaded Beams

Beams	a/d	RA (%)	Load (kN)		Reduction Due to RCA %		$\frac{P_{cr}}{P_u}$ %	Reserved Strength $\frac{P_u - P_{cr}}{P_{cr}}$ %
			Inclined Cracking (P_{cr})	Ultimate (P_u)	P_{cr} %	P_u %		
G1RB1	1.0	0	220	650	-	-	34	195
G1RB2		25	200	640	9	2	31	220
G1RB3		50	170	500	23	23	34	194
G1RB4		75	110	490	50	25	22	345
G2RB1	1.35	0	170	380	-	-	45	124
G2RB2		25	160	350	6	8	46	119
G2RB3		50	140	360	18	5	39	157
G2RB4		75	140	310	18	18	45	121
G3RB1	1.7	0	150	320	-	-	47	113
G3RB2		25	120	290	20	9	41	142
G3RB3		50	110	280	27	13	39	155
G3RB4		75	100	220	33	31	45	120

Table 8 Inclined Cracking and Ultimate Load for Directly Loaded Beams

Beams	a/d	RA (%)	Load (kN)		$\frac{P_{cr}}{P_u}$ %	Reserved Strength $\frac{P_u - P_{cr}}{P_{cr}}$ %
			Inclined Cracking (P_{cr})	Ultimate (P_u)		
DG1RB3	1.0	50	190	580	33	205
DG2RB3	1.35		150	400	38	167
DG3RB3	1.7		100	300	33	200

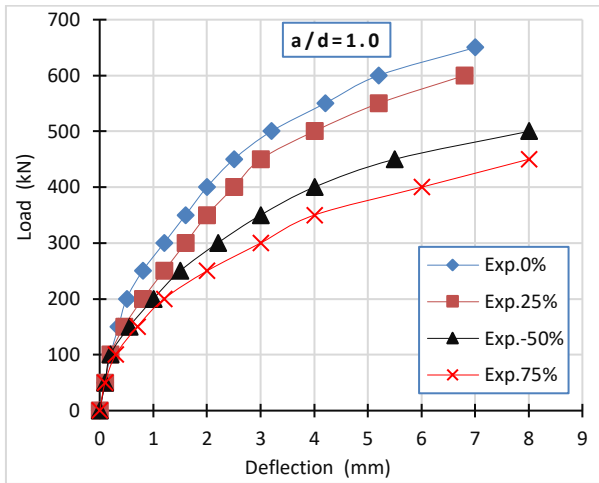

Figure 14: Load versus mid-span deflection curve for G1RB

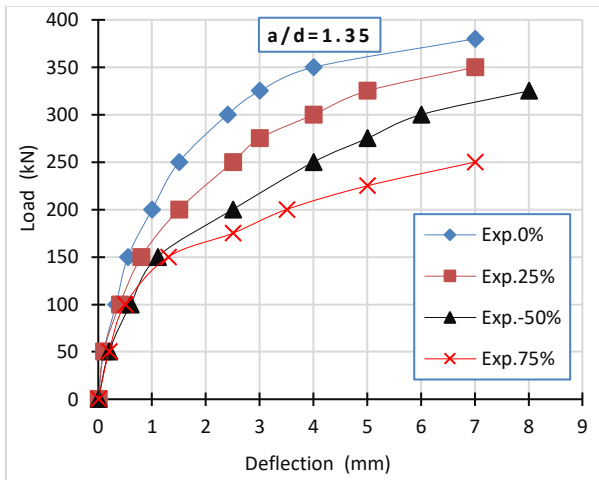

Figure 15: Load versus mid-span deflection curve for G2RB

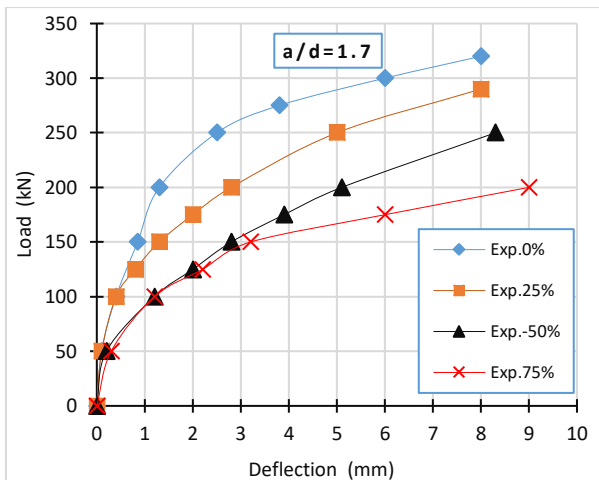

Figure 16: Load versus mid-span deflection curve for G3RB

13. Concrete Strains

The concrete surface strain was measured along the line between the applied load and the support. At the first stage of loading, the load concrete strain relationship was linear, but it became nonlinear for the later stage as shown in Figure 17. It was observed that the presence of any crack within or near the DEMEC discs is highly affecting the measured strain reading because the measurement represents the concrete strain and crack width. From the experimental results, it can be concluded that the beams made with recycled aggregate concrete have higher concrete strains as compared with beams made with natural aggregate concrete.

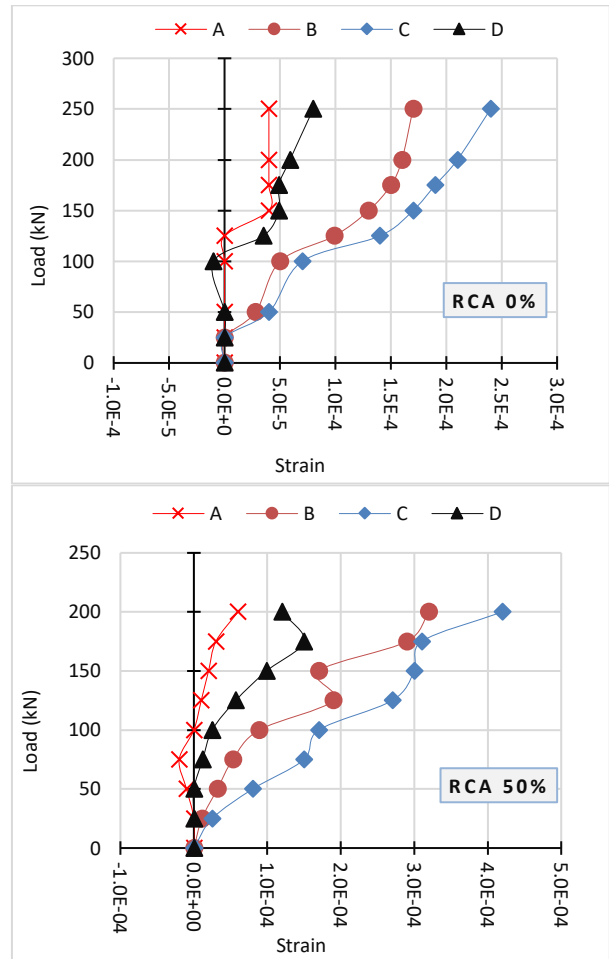

Figure 17: Effect of RCA% on concrete strain for indirectly loaded rectangular deep beam with ($a/d = 1.0$) in the first group (G1RB)

14. Summary and Conclusions

In this study, fifteen deep beams were tested to investigate the shear strength of directly and indirectly loaded rectangular self-compacted reinforced concrete deep beams containing recycled concrete as coarse aggregate. Two parameters considered in this study which were shear span to effective depth (a/d) ratio and replacement ratio of recycled concrete as coarse aggregate. It was observed from the experimental results for both, directly and indirectly, loaded beams that the compressive strength, splitting tensile strength, and modulus of elasticity was reduced by the increase of the RCA replacement ratio. As a result, the measured deflection was higher when the RCA was increased. Also, a higher strain was observed as the RCA was increased. The cracking and ultimate loads were decreased with the increase of the RCA replacement ratio. With RCA of (25%, 50% then 75%), the cracking load was decreased by (9%, 23%, and 50%) while the ultimate load was decreased by (2%, 23%, and 25%) for beams of the first group (G1RB). Similarly, the cracking and ultimate loads of the second group (G2RB) were decreased by (6, 18, and 18) and (8%, 5%, and 18%) with RCA replacement of (25%, 50% then 75%) respectively. The third group (G3RB) of beams experienced a reduction in the cracking and ultimate loads of (20, 27, and 33) and (9%, 13%, and 31%) with RCA replacement of (25%, 50% then 75%) respectively. The ultimate loads for rectangular indirectly loaded deep beams with RCA 50% the increase of (79%) is obtained by reducing (a/d) ratio of (from 1.7 to 1.0) and the increase was (39%) with reduction the (a/d) from (1.35 to 1.0). The ultimate loads for rectangular directly loaded beams with 50% RCA ratio, an increase of (48%) is obtained by reducing (a/d) ratio of (from 1.7 to 1.0) and the increase was (31%) with reduction the (a/d) from (1.35 to 1.0). The beams carried additional load after diagonal cracking.

References

- [1] Gagan and Agam, "Flexural Behavior of Reinforced Recycled Concrete Beams", International Journal of Research in Engineering and Technology, EISSN: 2319-1163 PISSN: 2321-7308 (2015).
- [2] Khtar, Ali Kadr, and Jamal Abdul Samad Khudhair. "Experimental Study of the Shear strength of Self Compacting Concrete T-Beams made with Recycled Concrete as Coarse Aggregate." University of Thi-Qar Journal 14.1 (2019): 31-52
- [3] Sulaiman, Emadaldeen A., and Jamal A. Samad Khudair. Experimental Study on the Behavior and Strength of Reinforced Concrete Corbels Cast with Self-Compacting Concrete Incorporating Recycled Concrete as Coarse Aggregate. International Journal of Civil Engineering and Technology (IJCIET) Volume 10, Issue 1, January 2019, pp.188–201, Article ID: IJCIET_10_01_018.
- [4] ACI Committee.237 R-07, "Self-Consolidating Concrete", Reported by ACI Committee 237, PP.1-30, (2007).
- [5] EFNARC, "The European Guidelines for Self-Compacting Concrete Specification, Production and Use", European Federation of Producers and Applicators of Specialist Products for Structures, May (2005).
- [6] ACI Committee. Building Code Requirements for Structural Concrete (ACI 318-19) and Commentary. American Concrete Institute, 2019.
- [7] Lafta, J., and Kun Ye. "Specification of Deep Beams Affect the Shear Strength Capacity." Civil and Environmental Research 8 (2016): 56-68.
- [8] Fereig, S. M., and K. N. Smith. "Indirect loading on beams with short shear spans." Journal Proceedings. Vol. 74. No. 5. 1977.
- [9] ACI-ASCE Committee 426. The Shear Strength of Reinforced Concrete Members. ACI Journal Proceedings, 1973, 99(6):1091-1187.
- [10] Paul, Iqbal Singh. Behavior of indirectly loaded reinforced concrete thin wall ribbed panels. Diss. Concordia University, 1978.
- [11] IQS No. 5/1984, "Portland Cement," Central Agency for Standardization and Quality Control, Planning Council, Baghdad, Iraq.
- [12] Standard Specification for Chemical Admixtures for Concrete. ASTM-C494-05, American Society for Testing and Material, (2005).
- [13] Iraqi Specification No.45, "Natural Sources for aggregate that is used in concrete and construction", Baghdad, (1984).
- [14] ASTM A615/A615M-04b, "Standard Specification for Deformed and Plain Carbon Steel Bars for Concrete Reinforcement", (2004), PP. 1–6.
- [15] Jin, Jinhua, "Properties of Mortar for Self-Compacting Concrete" Ph.D. Thesis, Department of Civil and Environmental Engineering, University of London, 2002.
- [16] De Paiva, H. A., and Chester P. Siess. "Strength and behavior of deep beams in shear." Journal of the Structural Division 91.5 (1965): 19-41.
- [17] Kong, F. K. "Shear analysis and design of reinforced concrete deep beams." The Structural Engineer 50.10 (1972): 405-409.
- [18] Park, Robert, and Thomas Paulay. Reinforced concrete structures. John Wiley & Sons, 1975.
- [19] Shah, R. H., and S. V. Mishra. "Crack and deformation characteristics of SFRC deep beams." Journal of the Institution of Engineers. India. Civil Engineering Division 85.mai (2004): 44-48.
- [20] Guadagnini, Maurizio, Kypros Pilakoutas, and Peter Waldron. "Shear performance of FRP reinforced concrete beams." Journal of reinforced plastics and composites 22.15 (2003): 1389-1407.