



University of Anbar



The effect of a controlled cooling system on the solar array of DC air conditioner

Hashim Abed Hussein^{a*}, Ali Hussein Numan^b, krar Mohammed.kuderc

^{a,b,c} *Electromechanical Engineering Department, University of Technology, Baghdad, Iraq.*

PAPER INFO

Paper history:

Received 1/9/2020
Received in revised form
23/9/2020
Accepted 5/10/2020

Keywords:

Cooling Photovoltaic, Direct Driven, Dc Air Conditioner, Arduino Controller, Dc Brushless Compressor And Test.

ABSTRACT

The present research is devoted to solve the problem of high energy consumption by air conditioners in summer. In order to eliminate domestic electricity for cooling purposes and rely directly on solar energy isolated from the grid connection and increases the performance of the solar panel by using front water spray cooling system for the panel, and by using Aduino as controller to control the cooling system. The experimental system setup arranged in Iraq at Al-taje site during the summer season at a room. The proposed system consists of an array of photovoltaic, battery used to store power, PWM charge controller, and DC air cooler, Aduino. During the examination of the system, The enhancement of the solar panel has a positive effect on long-term batteries and improves the battery life by which the charge and discharge when combined with a direct photovoltaic air conditioning system without refrigeration. Excess power generated from the PV panels is storage in the batteries, which make the system is the most familiar with Iraq's summer conditions.

1. Introduction

Iraq experiences insufficiency production in electrical power and several other challenges to meet the increasing demand for electrical power. In Iraq, air conditioners are popularly utilized in commercial and as well as residential buildings. Thus, electrical power consumption decreasing is believed as an imperative factor while designing air conditioner systems, which can be accomplished by enhancing the system's efficiency. Air conditioner system performance that operates at high ambient temperatures can be enhanced by decreasing the air conditioner compressor power consumption [1]. By utilizing solar energy, which has the advantages of inexhaustible, pollution free, along with small regional limitation. Solar energy becomes the most significant replacement of nonrenewable energy sources. Since 1990, the technology of solar photovoltaic started to evolve fast, by the continuous development of photovoltaic performance and the continuous prices drop of solar modules, the technology of solar photovoltaic is growing to be more widespread [2-3]. A large part of the solar energy that falls on PV modules is converted into thermal energy, and this thermal energy causes further deterioration in the performance of PV modules because of their high temperature [4]. Air conditioners with PV direct driven method is a

* Corresponding author: Hashim Abed Hussein ; ammar.dawood@gmail.com ; +9647804546332

collection of solar power generation technology and new cooling technologies, that can effectively transform solar power to air conditioner compressor during operation, furthermore, the excess power is used to charge the battery for night time or during cloudy days, therefore contribute considerably by save energy cost used from the grid. Thus, for power cost saving also emission reduction, solar powered air conditioners have incomparable benefits when compared to traditional air conditioners. Ahmed Amine Hachich et al study different scenarios of cooling system: front, back and double cooling under United Arab Emirates weather conditions. A spraying system is used for the front cooling whether a direct contact water system is used for the back cooling. The experimental results are compared to non-cooling module and the performance of the PV module is determined for different situations. The experimental results show that the front cooling is more effective than the back cooling and may decrease the temperature of the PV module significantly [5]. Zahratul Laily Edaris et al present study simple and efficient front water spraying cooling system in a photovoltaic panel. The performance of the proposed cooling system has been tested and evaluated for the weather climate of a city in Jitra Kedah, Malaysia. used 9 nozzles altogether installed with three 3 on the left and right side and the rest three 3 at the top of the PV panel, The PV module temperatures are measured with three thermocouples attached at the back, surface of the PV panel and ambience reading, used 100W polycrystalline SPV, two water pumps and tank and nozzles. The cooling water is stored in a tank connected to the cooling system through a ½ inch plastic hose pipe. Conclude water spraying over the panel able to reduce the cell temperature until 22 °C. The decreasing temperature leads to better PV power output efficiency by 10.5% [6]

2. Experimental Work

2.1. System Description

PV direct driven air conditioner system essentially combines; battery bank, PV array, PWM (pulse width modulation) charge controller, Arduino type Nano as shown in Figure 3, isolated tank, and DC air conditioner, which has a DCBL compressor. See Figure 1. PV array firstly generates electricity to meet air conditioning demand, the excess produced power stored in the battery bank to compensate for short in PV production during cloudy days or night ,but because of the hot weather of Baghdad city the solar panel suffered from losses because continues increase in temperature for surface of solar panel that will reduce the power product, that will leads the air conditioner depend on battery, that mean the battery will suffer from long time of discharge that damage battery and short life ,to solve this problem use cooling system

2.2. Photovoltaic System

Cooling load means the volume of heat that requires to be removed from the space per unit time. This is required for engineering air conditioning systems. The purpose of cold load requires to take into account the following four features, space area, number of people, type of activities in the space and additional cooling devices. Along with local climate parameters and buildings purposes, the primary calculation of the room load indicator is around 80Wm⁻². Solar panels transform sunlight instantly into electrical power through the photoelectric effect or photochemical effect. The PV array made of interconnected photovoltaic panels in series and parallel. PV panels essentially split into monocrystalline and polycrystalline silicon photovoltaic cells. In the presented study monocrystalline silicon cell utilized. PV modules made in Iraq at Al - Mansour / Al Zawra facility, which have technical parameters as shown in Table 1.

Table 1. Parameters of the solar module

Parameters	Value	Parameters	value
pmax	183.92 W	pmax	183.92 W
Voc	45.38 V	Voc	45.38 V
Vmp	36.73 V	Vmp	36.73 V

2.3. System Test

To study improve of PV efficiency by cooling and the effect of improve on the photovoltaic air condition system during the summer season, based on the above design, PV air conditioning system installed in a room which is 12 m² at Altaje site at Al - Mansour / Al Zawra facility. The proposed system utilizes eight panels with plastic pipe as show in fig 2(a), four solar batteries bank in series as in fig 3, dc air conditioner with brushless compres-

sor, water tank that isolate from environment temperature effect as show in figure 4, PWM solar charge controller, water pump , Arduino type Nano as show in fig 5. The present automated cooling system was designed to supply the water to the PV Panel when the temperature of PV is overheated. The water can be started to flow by opening an electronic DC motor linked by a hosepipe with the water supply tank and with a perforated pipe at the other end. The water is dripping on the PV panel front side to extract the undesirable heat through a perforated pipe. A plastic pipe with diameter of 10mm used to distribute the water through small perforations along it. The perforated pipe was fixated at the upper edge of the back surface of the module and connected to the supply hosepipe at one end while, the free end was closed as show in figure 2(b). The starting and stopping flow was controlled by using the electronic control circuit as show in figure 6. on 15 July 2019, the above system tested from 9:30am to 15:00pm .the test parameter; solar radiation intensity, PV power production, the state of charge of betties by measured the voltage .These parameters measured using solar radiation recorder, Digital multi-meter ,reading that show on solar charge controller that read the power produce from solar panel.

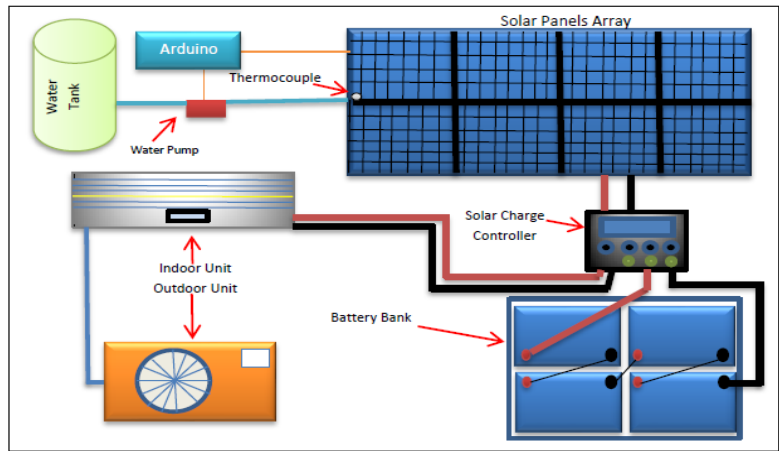

Figure 1: schematic of the solar air conditioner system



Figure 2: a- Cooling pipe installation, b- Cooling pipe installation on the PV array



Figure 3: Battery bank of four batteries in series



Figure 4: water tank

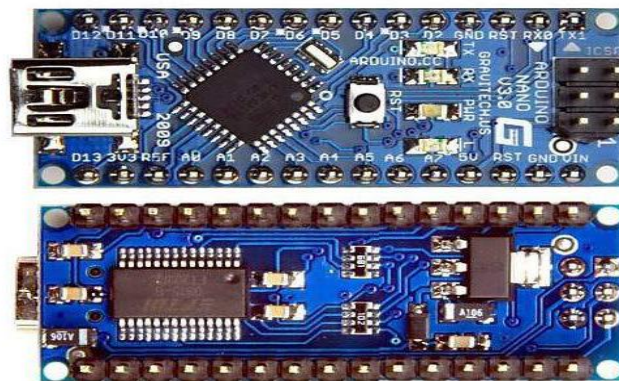

Figure 5: Arduino Nano circuit board

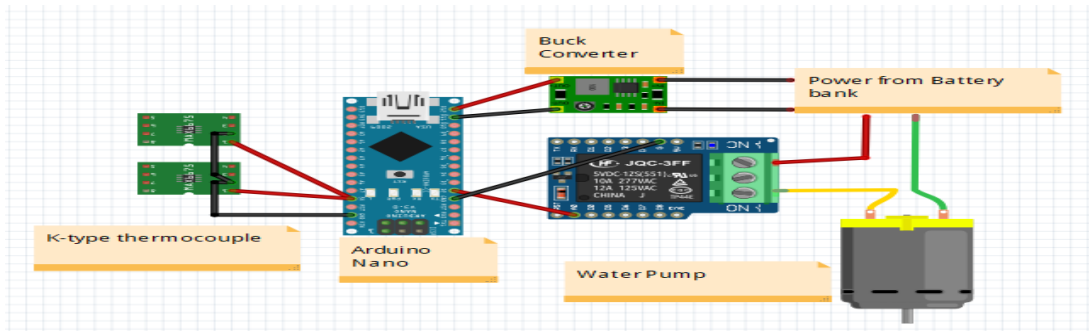

Figure 6: Arduino based PV cooling system diagram

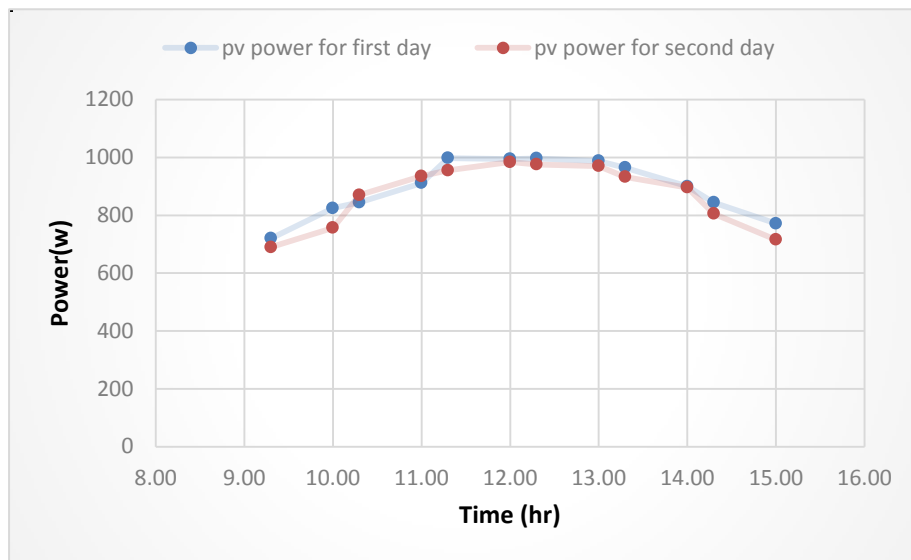

Figure 7: Comparison Between Solar Photovoltaic power with and without cooling

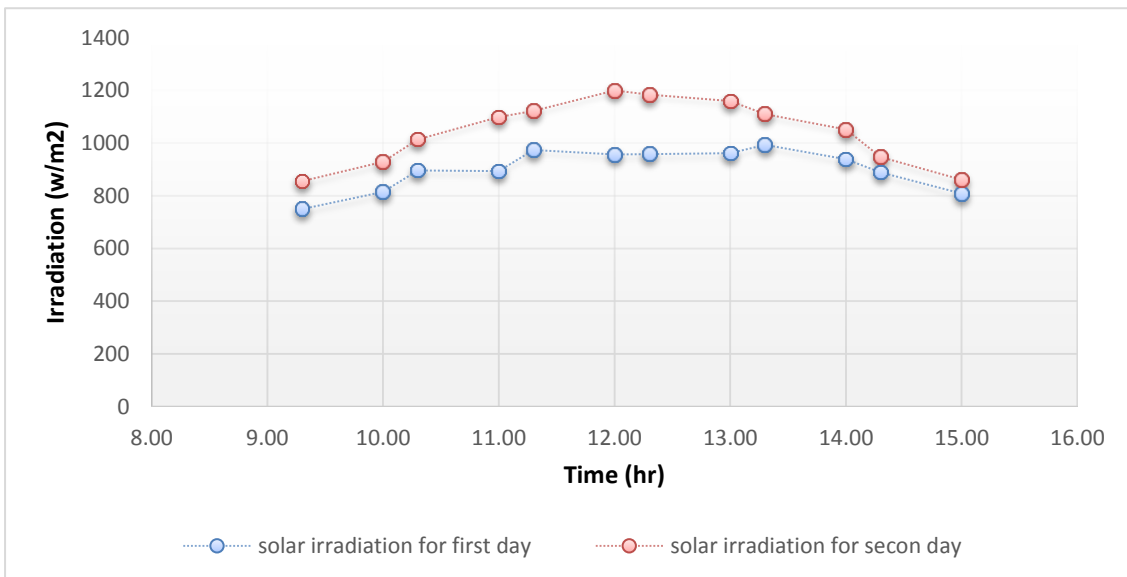

Figure 8: The Comparison between solar irradiation for first and second day

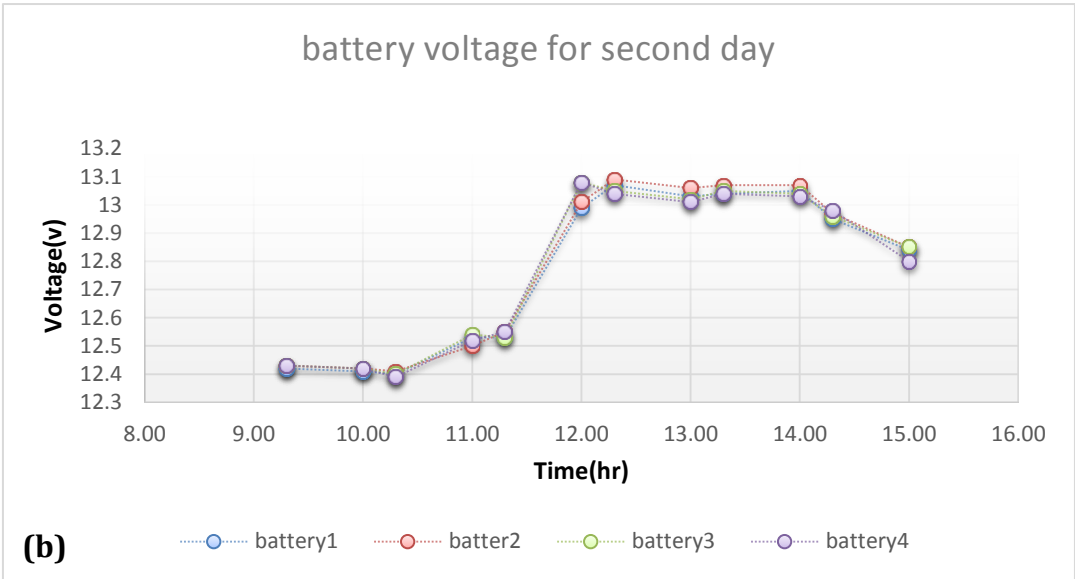
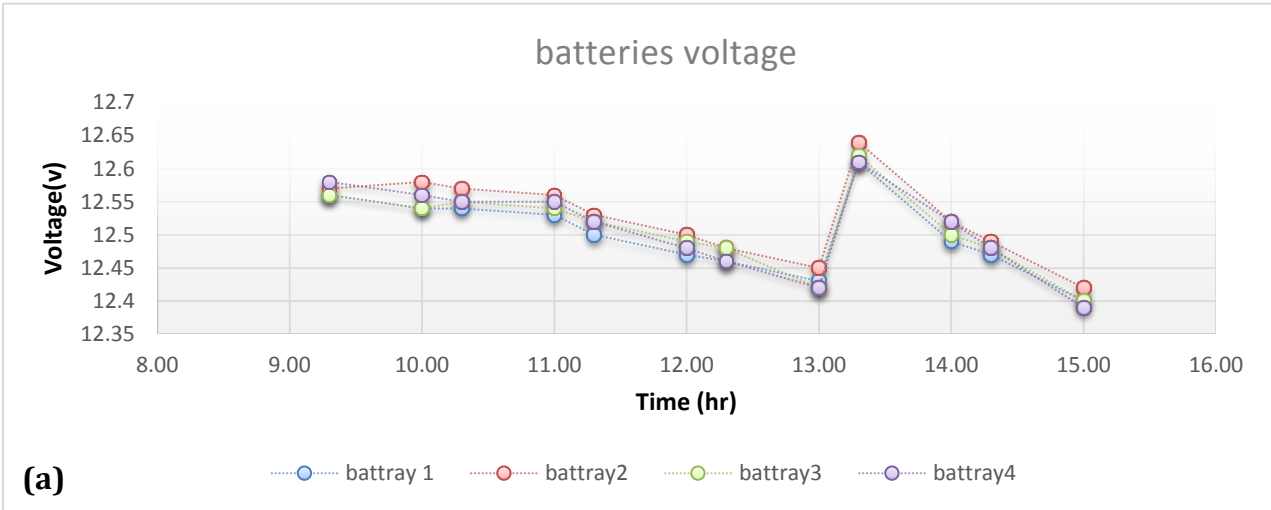

Figure 9: State of charge for: a- First day, b- Second day

3. Results and Discussion

1-The result of this test (second day) on 15 July 2019 is compare with the same system without adding cooling system (first day) that is take the result of it in on 12 July 2019 to show what the percentage of improvement of solar panel power production and the effect of adding cooling system on the solar photovoltaic direct driven air conditioner system. As show in figure 7 the comparison between the solar panel power with and without cooling. Comparing the first part take the output power of PV array from 9:30 am to 11:00 am for each first and second, the output power for the first day test was between 742.2 watt to 893.6 watt while for second test with cooling the output power was between 855 watt to 1098 watt, the cooling of PV array influenced the output power by 18.6 % increase at 11:00 am in the second day.

2- second part of cooperation The power output of PV array for 11:00am to 12:00pm the first day test was 893.06 W at 11:00am to 956 W at 12:00 pm but for second was from 1098 at 11:00 pm to 1199 at 12:00pm for the third day this is refer to improvement by 20.26% at 12:00 pm, as we see that the maximum value of solar panel power for the second day is occur at 12:00pm according to the maximum irradiation at 12:00pm but on the first day the maximum value of solar panel was at 1:30 although the irradiation was not the maximum this as show in figure 8 because the first day the solar panel was in high temperature proves the temperature can be negative effect high than irradiation on power produce after this time the solar power production for two day drop because the drop in solar radiation .

3- As show in figure 9 a that the state of charge of first day for four berries from 9:30am until before 13:30pm are suffered from continuous discharge because the solar power production was not enough for dc air conditioner so the dc air conditioner depend on the batteries to reparation the gap in solar power so the batteries did not charge in this time because the is not excess power of solar panel ,at 13:30pm the is little increase in batteries band voltage in mean the is charge for batteries because the solar panel was enough to provide the DC type air conditioner in power and the is excess power came from solar panel to charge batteries ,after this time returned drop in state of charge of batteries because the decrease in solar panel because the increase in solar panel temperature that become the solar power is not enough to provide the dc air conditioner in power so the discharge so discharge of batteries continuous until the end of test at 15:00pm .

4- State of charge of second day for four berries from 9:30am until before 11:00am the batteries was suffered from discharge because the power of solar panel was not enough to provide the dc air conditioner so the dc air conditioner depend on the batteries to reparation the gap in solar power, after 11:00am until 14:00pm the batteries continues to charge because there is excess power came from the solar panel to the batteries bank ,after 14:00 pm return the drop in batteries until the end of test at 15:00pm s show in figure 9.

4. Conclusion

1-the design power for the eight solar panel was 1440 watt when compared this value the maximum value of the solar panel produce in first and second day was 993 at 13:30pm for first day and 1199 watt at 12:00pm for the second day this led to the loss in first day was 31.04% for first day and 16.73%for second day the reduce in percentage of losses in power of solar panel for second day was because the cooling system that added to the solar panel that direct-driven air Conditioning system.

2- The maximum improvement that record for solar panel power product for the second days was at 12:00pm it was 20.26%.

3- The effect of improvement in solar panel power on system it show on the batteries that the batteries was less discharge in second day as comparison with first day and the barriers in second day was continues in charge for three hours this will increase barriers life and allow to the system to work longer time

Appendix

We extend our gratitude to the supports to Al - Mansour / Al - Zawra for solar panels.

References

- [1] Jamal Abdul-Kareem Mohammed, Farag Mahel Mohammed, Mustafa Abdul-Sattar Jabbar, Investigation of High-Performance Split Air Conditioning System by Using Hybrid PID Controller, Applied Thermal Engineering (2017).
- [2] Y. Li, G. Zhang, G.Z. Lv, A.N. Zhang, R.Z. Wang, Performance study of a solar photovoltaic air conditioner in the hot summer and cold winter zone, Solar Energy. 117 (2015) 167-179
- [3] M. Chandel, G.D. Agrawal, S. Mathur, A. Mathur, Techno-economic analysis of solar photovoltaic power

plant for garment zone of Jaipur city, Case Studies in Thermal Engineering. 2 (2014) 1-7.

- [4] Kahoul N., Houabes M., Sadok M., 2014. Assessing the early degradation of photovoltaic modules performance in the saharan region, Energy Convers. Manag. 82, (2014)320-326.

[5] Ahmed Amine Hachicha, Chaouki Ghenai, Abdul Kadir Hamid, Enhancing the Performance of a Photovoltaic Module Using Different Cooling Methods, International Journal of Environmental, Chemical, Ecological, Geological and Geophysical Engineering Vol:9, No:9, 2015.

- [6] Zahratul Laily Edaris ,Mohd Sazli Saad ,Mohammad Faridun Naim Tajuddin ,Experimental and simulated evaluation of temperature effect on panel efficiency performance with front water cooling ,978-1-5386-8369-9/18/\$31.00 ©2018 IEEE.