



University of Anbar

Anbar Journal of Engineering Science

journal homepage: <https://ajes.uoanbar.edu.iq/>



Review and Case Study on Control of Induction Motor Using High-Level Converter

Ayad T. Mahmood^a, Khalaf S. Gaeid^b

^a Department of the Electrical Engineering, College of Engineering, University of Tikrit, Iraq
Email: ayad.t.mahmood@st.tu.edu.iq; ORCID: <https://orcid.org/0009-0006-9011-7182>

^b Department of the Electrical Engineering, College of Engineering, University of Tikrit, Iraq
Email: gaeidkhalaf@gmail.com; ORCID: <https://orcid.org/0000-0002-8943-3034>

PAPER INFO

Paper History

Received: 31/01/2024

Revised: 13/04/2024

Accepted: 22/04/2024

Keywords:

Matrix Converter (MC)

Space Vector Pulse Width Modulation (SVPWM)

Space Vector Modulation (SVM)

Direct Torque Control (DTC)

Induction Motor (IM)

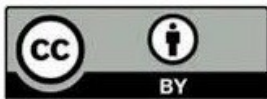

Copyright: ©2023 by the authors. Submitted for possible open access publication under the terms and conditions of the Creative Commons Attribution (CC BY-4.0) license.

<https://creativecommons.org/licenses/by/4.0/>

ABSTRACT

Matrix converters (MCs) have attracted significant interest and found extensive applications across multiple industries owing to their desirable characteristics. These include the capability to produce sinusoidal currents at both input and output, substantial size reduction, and enhanced reliability by minimizing significant passive components. This paper explores the potential of MC technology as a viable alternative to conventional AC-DC-AC converters in industrial applications. It discusses recent advancements in MC structural configurations, modulation/control algorithms, and multiphase structures and control systems. The paper offers an in-depth review of modern industrial uses of MC technology. It also delves into different methods for managing induction motors, particularly the DTC (Direct Torque Control) approach. The study explores the intricacies of DTC and its relationship with SVM. The primary research objective is to examine the performance of an IM when operated with an SVPWM inverter, focusing on harmonic analysis of voltages and currents. Various PWM methods regulate the voltage and frequency supplied to the IM. Sinusoidal Pulse Width Modulation (SPWM) and SVPWM are the two most commonly used 3-phase Voltage Source Inverter strategies. The growing adoption of SVPWM is driven by its ability to reduce harmonic content in voltage and enhance the fundamental output voltage of the IM. Consequently, this study models a DTC-SVM theory-driven IM using MATLAB/SIMULINK to control the speed of induction motors. The following values were calculated for the system: Quality factor=2.236, Damping ratio=4.45, and the cut-off frequency ($f_c=355.88\text{H}$).

1. Introduction

A range of configurations exists for direct power frequency converters, among which the matrix converter (MC) is a prevalent choice. The concept

of the MC was first introduced by Venturini and Alesina in 1980. The basic design of an MC incorporates bidirectional power switches arranged in a matrix formation. This setup connects

* Corresponding author: Ayad T. Mahmood; ayad.t.mahmood@st.tu.edu.iq; +964-07702178708

each phase of the load to the respective phases of the source, enabling efficient power conversion. This pioneering configuration, introduced by Venturini and Alesina in 1980, not only coined the term "matrix converter" but also established the groundwork for related control theories. An input filter in the MC is recommended to enhance operational efficiency, minimize high-frequency components, and align with control principles, often called Venturini modulation. This modulation relies on a matrix operating at low frequencies, discussing the lower frequency characteristics of MC voltage and current. Notably, it includes a limit on the output voltage, featuring 0.5 input voltage and a controlled power factor. Venturini and Alesina later improved this theory by introducing harmonics at the third order into input current and output voltage patterns, known as the optimal Venturini method or improved Venturini. This advancement effectively achieves a voltage transfer ratio of 0.866 at its peak. Both versions of Venturini modulation, commonly known as the direct transfer function technique, determine the output electrical voltage by multiplying the modulation matrix with the input voltages [2], three-phase Matrix Converters, also known as direct AC-AC converters [3], have emerged as a promising alternative to well-established Voltage Source Inverters (VSIs). The inherent advantages of Matrix Converters (MCs), such as bidirectional energy transfer, adjustable power factor at the input, a high power-to-size ratio, and the absence of bulky DC-link capacitors, have attracted considerable attention. While previous research has primarily focused on modulation and switching techniques for MCs, there has been a relatively limited exploration into achieving efficient speed regulation for Induction Motors (IM) with optimal performance when powered by MCs. Initially, Casadei proposed a DTC approach for IMs powered by MCs validated through experimental studies. However, certain limitations have been identified, including operations with varying frequencies, torque fluctuations, and flux fluctuations. Various switching-based techniques, tables, and constant switching frequencies have been applied in DTC to address these challenges. Recommendations include utilizing the space vector approach, a flux deadbeat method, and direct torque control to reduce torque fluctuations and achieve a unity input power factor, as suggested in prior research [4].

The DTC algorithm [5], originating in the 1980s, initially gained prominence in the induction motors industry. Over time, as the emphasis in the motor industry shifted toward enhanced efficiency and compact design, the application of the DTC algorithm expanded to synchronous motors. The DTC calculation monitors the motor's torque force and magnetic field strength as a control technique using a hysteresis controller and a reference table (look-up table) [6]. Despite its advantages, the conventional torque control algorithm, which depends on a hysteresis-based control system and a reference table, has a significant limitation: it leads to torque ripple due to its failure to consistently maintain the angular disparity between the stator and rotor flux during motor operation. Several control strategies have been proposed to overcome this challenge. A modulation technique, Direct Torque Control (DTC) with Space Vector Modulation (SVM), has been developed. This technique enables the immediate preservation of a constant load angle, aligning with the position of the stator flux [7].

The Space Vector Modulation (SVM) technique [8], a form of Pulse Width Modulation (PWM) based on space vector theory, has significantly advanced industrial power conditioning equipment in recent years, adapting to meet the changing demands of the automation industry [9]. Since its introduction, Space Vector Pulse Width Modulation (SVPWM) has consistently outperformed conventional Pulse Width Modulation (PWM) techniques regarding efficiency and effectiveness. It has undergone continuous development and has now reached a remarkable peak. SVPWM enables a range of power converter topologies and applications, including AC/AC matrix converters, Current Source Inverters (CSI), cyclo converters, load-commutated inverters, DC-to-DC converters, and diode/thyristor-based rectifiers [10].

SVPWM stands out for its efficient DC bus utilization, a crucial advantage for electric vehicles (EVs) that target high speeds. It notably improves DC bus voltage use by 15.5% over sine PWM with a modulation index of one, underlining its effectiveness in this area [11], for three-phase inverters using enhanced SVPWM, the reduction in odd-order PWM frequency noise is more significant than with the modified SVPWM [12], the suggested SVPWM method simplifies implementation by avoiding complex zone and angle calculations, making it more straightforward than the traditional SVPWM approach [13]. While SVPWM has notable

advantages, it also faces challenges, such as the computational complexity in determining the reference voltage vector position and the need for substantial storage to maintain records of switching states and duty cycles [14]. To boost the efficiency of SVM-based systems, control strategies such as DTC, vector control, and predictive control algorithms have been introduced [12- 13].

2. An Overview of Matrix Converter Technology

Matrix Converters (MCs) are direct AC-AC converters that can generate a range of output frequencies, as illustrated in Fig 1. Initially recognized for their use of IGBTs (Insulated Gate Bipolar Transistors) and MOSFETs (Metal-Oxide-Semiconductor Field-Effect Transistors) in forced commutated cyclo converter configurations, MCs offer a distinct advantage over traditional cyclo converters.

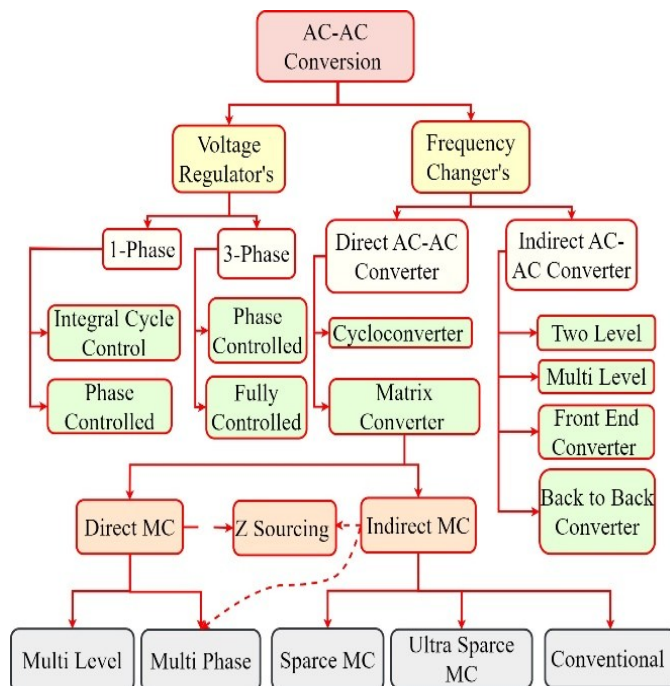

Figure 1. Categorization of AC-AC converters and their different variations.

The latter typically employ thyristors and are constrained to operate at standard input frequencies, such as 50 or 60 Hz. MCs are divided into Direct Matrix Converters (DMC) and Indirect Matrix Converters (IMC), where DMCs connect outputs directly to inputs, and IMCs use a DC link.

Both types need a similar number of switches and can be configured in $m \times n$ formats [17].

Fig 2. (a) shows a Direct Matrix Converter (DMC), and Fig 2. (b) features an Indirect Matrix Converter (IMC) with multi-phase inputs and outputs. They are arranged in a 3×3 matrix, using 18 IGBT switches. The DMC is designed for bidirectional current flow and bipolar voltage blocking. More details on these switches and MC components will be covered later in the text; traditionally, converting a stable AC source into a variable voltage and frequency AC output involves voltage source inverters, rectifier circuits, and large DC link capacitors. However, matrix converters (MCs) eliminate needing a DC link capacitor. This significant advancement in MC topology allows for converting a stable AC input into a desired AC output with adjustable voltage and frequency, all without relying on a DC link capacitor [18]. Matrix converters (MCs) offer several key benefits: They generate sinusoidal input and output currents, allow for a controllable phase shift factor, and have the capability for energy regeneration. Additionally, eliminating the DC link in MCs leads to further advantages: Enhanced reliability, lower maintenance needs, simplified circuit design, reduced weight-effective operation in high-temperature environments, and reduced voltage stress on the switches [19].

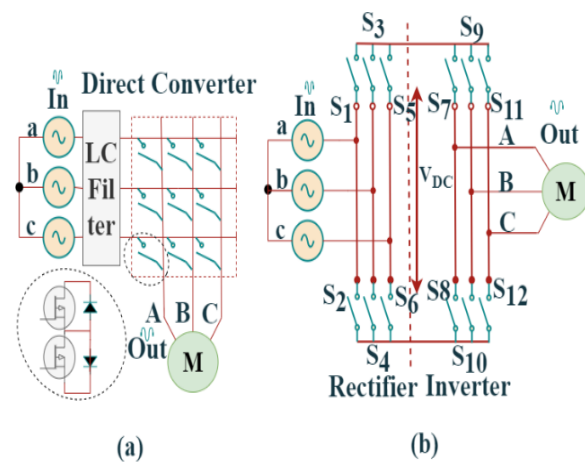

Figure 2. (a) Direct matrix converter (b) Indirect matrix converter.

AC-AC frequency converters can be divided into three main categories, as shown in Fig 3. However, it's important to note that the specific terms and classifications might vary in technical literature due to the continuous evolution of converter technologies:

1. Direct Structures with DC Energy Storage: This category includes converters incorporating significant DC power storage components.
2. Direct Configurations without DC Power Storage: Solid-state power switches connect this group's input and output terminals. They often include minimal capacitors and inductors for efficient operation, such as high-frequency filters or adequate regenerative AC energy storage.
3. Direct Frequency Converters with Limited DC Power Storage or Supplementary Modules: This category combines direct frequency converters with limited DC power storage or an additional module, such as a DC-DC boost converter. These configurations are less common but represent a growing trend in AC-AC frequency converter technology [20].

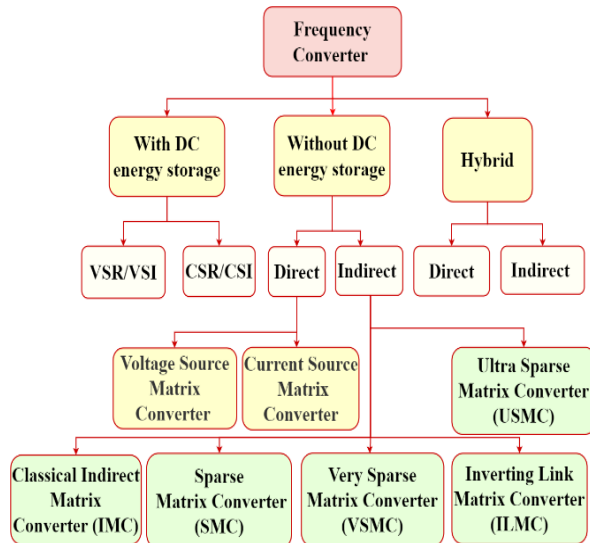

Figure 3. Categorization of 3-phase AC-AC converter configurations.

3. Comparing DMCs to Traditional AC-DC-AC conversion

The presentation will delve into Direct Matrix Converters (DMC) and Indirect Matrix Converters (IMC), examining their current status and notable recent advancements. This contribution includes thoroughly examining modulation techniques, drawing from a wide range of literature on matrix converters and their modulation strategies. Furthermore, the presentation will highlight practical recommendations for the technological implementation of these converters.

3.1 Matrix Converter with Direct Configuration

The DMC is a single-unit system characterized by an array of bidirectional switches arranged in an m -by- n matrix. This design enables the connection of an m -phase voltage source to an n -phase load. Notably, the 3-phase to 3-phase Matrix Converter is a standard configuration typically used for linking a three-phase power source (like an electrical grid) to a three-phase load, such as a motor. The core circuitry of a 3ph-3ph MC consists of nine bidirectional switches, organized into three sets of three switches, each as shown in Fig 4. (a), known as switching cells. This setup provides a versatile way to connect the input phases (labeled a, b, c) to the output phases (A, B, C), forming a grid-like structure where rows and columns correspond to different stages. In diagrams, such as in Fig 4. (b), these bidirectional switches are often represented as circles, illustrating the connections they facilitate between the input and output phases.

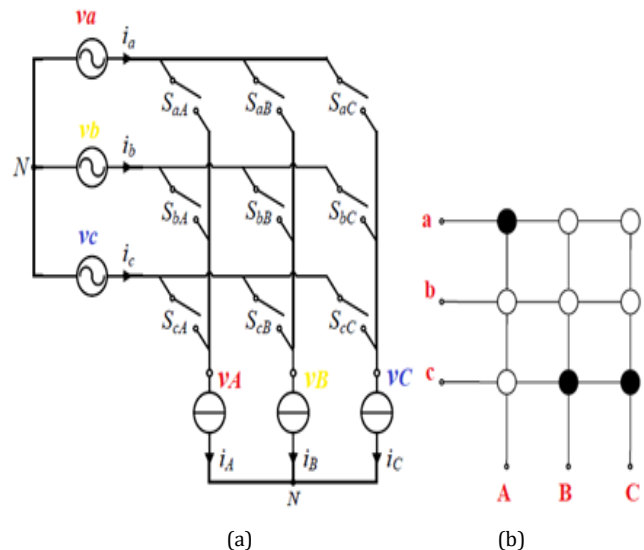

Figure 4. Configuration of the DMC (a) Illustrated diagram (b) Symbolic representation.

The matrix converter operates through the mathematical utilization of the switching function. This function determines the connection between input phase i and output phase j , taking 1 for closed and 0 for open devices, as defined in the reference [21].

$$S_{ij}(t) = \begin{cases} 1 & S_{ij} \text{ closed} \\ 0 & S_{ij} \text{ open} \end{cases} \quad i = \{a, b, c\}, j = \{A, B, C\} \quad (1)$$

3.1.1 Mathematical Model of DMC

For MC modulation techniques, start by establishing a mathematical model. The voltages at the input and output, concerning the input's neutral connection (as shown in Fig 4. (a)), are represented by these vectors:

$$v_i = \begin{bmatrix} v_a \\ v_b \\ v_c \end{bmatrix} \text{ and } v_o = \begin{bmatrix} v_A \\ v_B \\ v_C \end{bmatrix} \quad (2)$$

The variables i_a , i_b and i_c depict the input phase currents, while, V_a , V_b and V_c represent the phase voltages generated by the matrix converter [22].

The relationship between the input voltages (v_a , v_b and v_c) and output voltages (V_a , V_b and V_c) can be expressed using the following equation:

$$\begin{bmatrix} V_a \\ V_b \\ V_c \end{bmatrix} = \begin{bmatrix} S_{Aa} & S_{Ab} & S_{Ac} \\ S_{Ba} & S_{Bb} & S_{Bc} \\ S_{Ca} & S_{Cb} & S_{Cc} \end{bmatrix} * \begin{bmatrix} v_a \\ v_b \\ v_c \end{bmatrix} = K \begin{bmatrix} v_a \\ v_b \\ v_c \end{bmatrix} \quad (3)$$

The relationship between the input current (i_a , i_b and i_c) and the output currents (i_A , i_B and i_C) can be expressed using the following equation [23]:

$$\begin{bmatrix} i_a \\ i_b \\ i_c \end{bmatrix} = \begin{bmatrix} S_{Aa} & S_{Ba} & S_{Ca} \\ S_{Ab} & S_{Bb} & S_{Cb} \\ S_{Ac} & S_{Bc} & S_{Cc} \end{bmatrix} * \begin{bmatrix} i_A \\ i_B \\ i_C \end{bmatrix} = K^T \begin{bmatrix} i_A \\ i_B \\ i_C \end{bmatrix} \quad (4)$$

$$\sum_{x=A,B,C} K_{xx} = 1, (x = a, b, c) \quad (5)$$

Where K (transpose K^T) is the switch matrix. Other variables are denoted in Fig 4. (a). The elements K_{xx} within the switch matrix can be set to '1' for ON and '0' for OFF.

By manipulating the switch matrix, regulating both the input current and output voltage. To prevent the occurrence of invalid switch states that could lead to disconnecting the input sources or leaving the loads open-circuited, constraint (5) is implemented. These undesirable switch states can potentially cause harmful instances of overvoltage and overcurrent [24]

The motor control system utilizes Direct Torque Control (DTC), based on the foundational principles of traditional DTC methods. It further incorporates a hysteresis controller to regulate the input power factor, aiming to keep it at unity. This regulation is facilitated by the use of a hysteresis comparator. Within the framework of standard DTC operation,

the Matrix Converter executes two commutations at any given instant, regardless of the sector of the input voltage vector. This ensures synchronization with any chosen output vector of the Voltage Source Inverter (VSI), maintaining optimal control and efficiency in the motor operation. These commutations are crucial for modulating the input power factor, as they allow for the angle adjustment by both incrementing and decrementing, thereby ensuring effective control [25]. When analyzing the input voltage sector, it's noteworthy that pair-switching states can generate voltage vectors with matching directions. For example, in sector 1 of the input voltage, switching states +1 and -3 can create an output voltage aligned with v_1 (see Fig 5.). Table 1 clarifies the connection between voltage vectors and switching conditions within the DTC method across different voltage sectors [26].

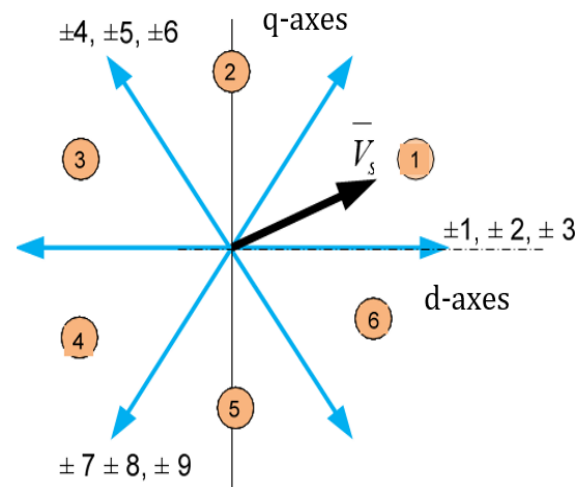

Figure 5. Shows active voltage vector arrangement in the MC's dq plane.

Table 1. Illustrates six hexagonal states, each linked to particular phase voltages and spatial characteristics.

voltage vector	Voltage sector					
	a	b	c	d	e	f
V1	-3, +1	+2, -3	-1, +2	+3, -1	-2, +3	+1, -2
V2	+9, -7	-8, +9	+7, -8	-9, +7	+8, -9	-7, +8
V3	-6, +4	+5, -6	-4, +5	+6, -4	-5, +6	+4, -5
V4	+3, -1	-2, +3	+1, -2	-3, +1	+2, -3	-1, +2
V5	-9, +7	+8, -9	-7, +8	+9, -7	-8, +9	+7, -8
V6	+6, -4	-5, +6	+4, -5	-6, +4	+5, -6	-4, +5

3.1.1 Potential Switching Configurations

Unlike traditional Voltage Source Converters (VSCs), matrix converters do not possess inherent paths for free-wheeling. This lack complicates securely transitioning between allowable states in a switching unit, adding complexity to their operation. The ideal scenario involves an immediate and synchronized exchange between the reversible switches to adhere to the restriction outlined in equation (6). Unfortunately, practical constraints emerge due to delays in signal propagation within control circuits and the finite durations of power semiconductor switches.

$$S_{aM} + S_{bM} + S_{cM} = 1 \quad M = \{A, B, C\} \quad (6)$$

To clarify further, the fundamental circuit for the exchange of the switching unit is illustrated in Fig 6.

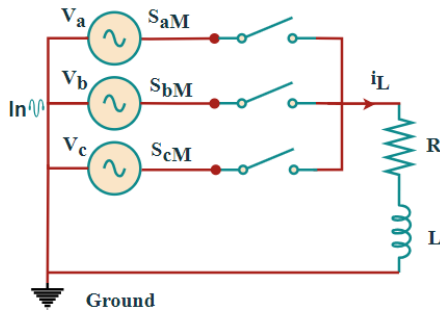

Figure 6. Fundamental switching cell commutation circuit.

This circuit incorporates three bidirectional switches connecting hypothetical voltage sources to output phase M, which subsequently powers an RL load. The secure transition between these switches follows two fundamental principles:

1. Avoid simultaneous connection of two devices to a standard output line to prevent potential short circuits from input voltage sources.
2. Ensuring there is always at least one active device to facilitate the flow of inductive load current, thereby mitigating the risk of excessive voltage events.

The matrix converter provides 27 switching arrangements, detailed in Table 2, which can be categorized into three distinct groups:

- I. Null vectors and zero magnitudes, denoted as 0a to 0c.
- II. Rotating vectors with a fixed magnitude but variable direction, spanning from ± 10 to ± 12 .
- III. Active vectors with a fixed direction but variable magnitude, ranging from ± 1 to ± 9 [27].

This control scheme utilizes exclusively active and null setups, making up a combined count of 18 permissible setups. The visual depiction in Fig 7. illustrates 21 switch configurations. The active setups, which correspond to non-zero voltage and current vectors, are denoted as follows: $(\pm 1, \pm 2, \pm 3)$, $(\pm 4, \pm 5, \pm 6)$, and $(\pm 7, \pm 8, \pm 9)$ [28].

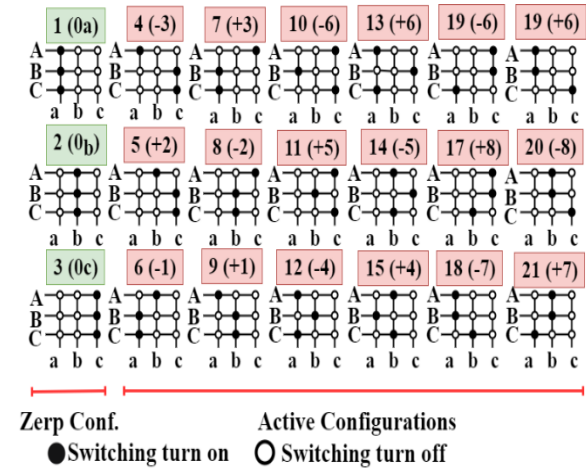

Figure 7. The graphical depiction of the utilized switching setups in the MC.

Matrix converters offer distinct advantages over other types of converters used in drives. One key advantage is the absence of bulky energy storage devices, resulting in a smaller physical size. Additionally, matrix converters exhibit superior input power quality, including a displacement power factor that ensures sinusoidal waveforms for output voltages and input currents and an input displacement factor of unity. However, like any other converter, matrix converters introduce switching actions that can distort the input current, resulting in harmonic components. This distortion can impact network voltages and affect other systems. An input filter must be incorporated into the converter design to mitigate these issues. This filter serves to comply with design standards, limiting electromagnetic interference and suppressing sudden transient voltages from the power supply. Implementing such a filter improves the converter's reliability and the protection of the load, leading to enhanced overall system reliability [29].

3.1.3 Overview Modulation Approaches for DMC

The choice of altering a signal employed for managing bidirectional switches directly impacts MC

technology's overall effectiveness and productivity [30]. Numerous modulation strategies have been suggested for matrix converters since Pelly and Gyugyi advanced the initial control theory in 1976 [31]. The evolution of MC modulation has progressed from intricate modulation equations rooted in transfer function methodologies to contemporary SVM techniques. Fig 8. provides an overview of modulation approaches for matrix converters [32].

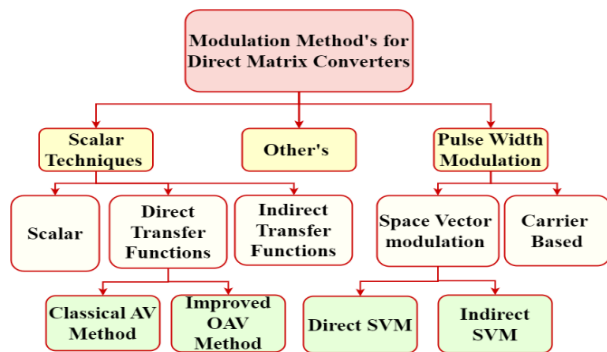

Figure 8. Matrix Converter Modulation Techniques Categorization.

Venturini modulation became the primary method for DMCs, evolving from Alesina and Venturini's pioneering work dating back to 1980 [33]. While this method showed superior performance compared to traditional control approaches, it had limitations due to a maximum VTR of 0.5. However, by late 1980, these two scholars introduced an upgraded control algorithm to address this constraint [34], the Alesina-Venturini modulation was enhanced by incorporating a harmonic component into the output reference voltage, leading to the development of the Optimized Alesina-Venturini method. This advanced approach increased the maximum VTR to 0.866, equivalent to $\sqrt{3}/2$. As the reference outlines, this value represents the theoretical limit for achieving sinusoidal input and output currents while maintaining complete control over the input power factor [35].

In 1983, Rodriguez introduced the "fictitious DC-link" concept as a novel modulation approach for DMCs [36]. This indirect technique divides the matrix converter into rectifier and inversion stages, effectively allowing for an elevation surpassing the 0.866 limits observed in other techniques for maximum voltage transfer ratio [37]. Ziogas et al.'s research contributions in 1985–1986 elevated the max voltage transfer ratio to 1.052, albeit at the

compromise involving distortion in low-frequency current harmonics [38].

In 1989, Roy devised the scalar modulation technique [39], utilizing the momentary voltage relationship between particular voltage inputs to produce commands for switching. A notable drawback of this algorithm's essence is its dependence on precise measurement of instantaneous input voltages for magnitude comparison [40].

In 1993, Casadei. Introduced an alternative SVM approach for MCs in [41]. Instead of portraying the MC as a two-stage system with a hypothetical DC-link, the authors depict all switch configurations within the stationary ab frame. Therefore, this study will delve into the DSVM, Known as SVM, as it represents the standard space vector modulation technique [42].

3.1 Matrix Converter with Indirect Configuration

In 1983, Rodriguez introduced the "fictitious DC-link" concept for controlling Direct Matrix Converters [43]. Building on this idea, Holtz and Boelkens proposed a novel configuration 1989 that practically implements the direct matrix converter while utilizing indirect modulation [44]. This reconfiguration of the DMC switches explored the notion of the "fictitious DC-link" [45]. As a result, this configuration is termed the IMC, serving as a substitute for the DMC by offering equivalent advantages and limitations [46]. The diagram illustrating the IMC topology is presented in Fig 9.

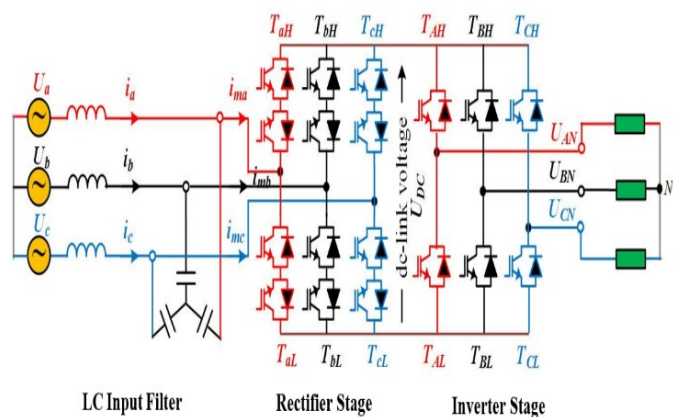

Figure 9. Topology of an indirect matrix converter.

The IMC comprises two main parts: the source-side and load-side converters. The source converter uses a 3-phase-to-1-phase setup with six bidirectional switches, functioning as a Current Source Rectifier (CSR) to produce sinusoidal input currents and stabilize the DC bus voltage. The load-side converter employs a standard three-phase VSI design with six unidirectional switches for generating output voltages. This setup involves 18 power switches and 18 diodes, similar to the direct matrix converter. However, unlike the direct MC's reliance on bidirectional switches, the IMC simplifies implementation by allowing standard six-pack power modules for the inverter stage. Additionally, the IMC can reduce active switches on the source side to as few as three, particularly when bidirectional power flow is not required [47].

Instantaneous Model Control (IMC) adopts an indirect SVM method, utilizing immediate space vector techniques to represent input and output voltages and currents. In IMC's dual-stage layout, modulation for both the source and load bridges is independently executed, with the calculated duty cycles combined to achieve modulation at a high switching frequency. This frequency ensures the stability of input current and output voltage reference vectors throughout the switching cycle. The switching functions for the source bridge's input phases a, b, and c are defined as S_{wa} , S_{wb} , and S_{wc} , respectively.

Under constraint (6), it's important to note that direct connections between input phases are prohibited. Thus, the switching functions are restricted to three distinct values: '1' indicates a connection between the input phase and the upbeat DC-bus bar 'p' via the upper switch, '0' represents both switches being off, and '-1' signifies a connection from the input phase to the negative DC-bus bar 'n' via the lower switch. Due to the requirement of connecting only one input phase to each bar at a time, as outlined in equation (7), the input switching operations must adhere to this protocol [48].

$$S_{wa} + S_{wb} + S_{wc} = 0 \quad (7)$$

4. Exploring DTC -SVM Concept

The idea of space vectors, originating in the rotating domain of induction motors, finds application in the modulation of inverter output voltage. In this technique, the three-phase values are converted into

their respective two-phase equivalents, either in a frame that rotates in synchrony or a stationary frame [49]. The fundamental framework of the DTC-IM system is depicted in Fig 10. The underlying fundamental concept of the DTC method can be explained as outlined below: Initially, the system measures phase currents and voltages. These measurements are sent for the flux and torque estimation module, which calculates the real system flux and torque values. The computed torque is subsequently contrasted to its reference values in the torque controller, while the actual flux is contrasted against the reference flux values in the controller. The control signal for the IGBTs is generated using the outputs from the stator flux and torque controllers, serving as inputs for the DTC switching look-up table [50].

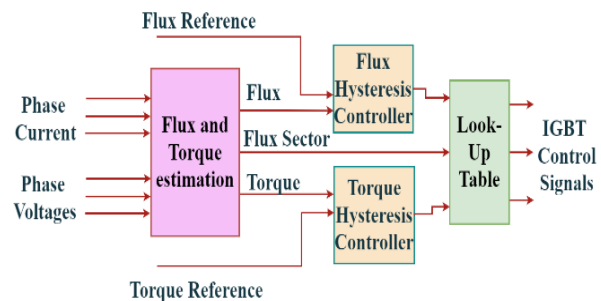

Figure 10. Block diagram of DTC.

Table 2 illustrates a range of control techniques developed over the last decades for (SVPWM). It emphasizes their impact on an inverter's output voltage and current while describing different sequences and their performance in two- and three-level inverters used in driving induction motors.

Table 2. Shows the difference between the SVPWM and SPWM techniques.

Ref.	Reduction	Current THD	Voltage THD
[51]	SPWM	Reduced Total Harmonic Distortion (THD) compared to SVPWM methods	
	SVPWM	19.25%	33.08%
[52]	SPWM	16.65%	14.15%
[53]	SPWM	12.95%	14.25%
	SVPWM	11.46%	11.43%

5. Mathematical Model of the System

The identification tool on overall MATLAB/SIMULINK to find the state space representation of

the closed loop system, the state space given in equations (8-9):

$$\frac{dx}{dt} = Ax(t) + Bu(t) + Ke(t) \tag{8}$$

$$Y(t) = Cx(t) + Du(t) + e(t) \tag{9}$$

The parameters (A, B, C, D, and K) are illustrated below:

A	x_1	x_2	x_3	x_4
x_1	-3.1e-05	-5.6e-05	-9.6e-07	4.2e-06
x_2	-0.000243	0.000399	-0.00199	0.0222
x_3	0.002382	0.001344	-0.00578	0.0649
x_4	0.002382	0.007273	-0.00460	-2.196
B	u_1	u_2	u_3	
x_1	21.61	21.61	21.61	
x_2	0.001877	0.001667	0.001465	
x_3	0.01298	0.01236	0.01177	
x_4	-0.05497	-0.03422	-0.01425	
C	x_1	x_2	x_3	x_4
y_1	2843	-	-	6.765e-05
		0.131	0.001393	05
		4		
y_2	3009	-382.6	128	-
				0.00393
				2
D	u_1	u_2	u_3	
y_1	0	0	0	
y_2	0	0	0	
and				
K	y_1	y_2		
x_1	0.0004029	7.335e-08		
x_2	-0.5138	-0.0004246		
x_3	-1.588	0.007111		
x_4	-61.84	1.66		

6. Case Study and Result

This study used a matrix converter with 18 IGBTs to control an IM, employing SVM-DTC technology for fast, effective problem-solving. All IGBT signals were suppressed to prevent electrical interference, and an appropriate input filter ensured undistorted current and voltage signals, achieving a unity power factor. The motor's speed was precisely controlled with rapid response due to SVM-DTC. Simulations with a 20-microsecond interval tested the method, using a 4 KW squirrel-cage IM ($P_i=3.5kW$, $V_n=480V$, $R_s=0.80\Omega$, $R_r=0.85\Omega$, $L_s=2.1mH$, $L_r=1.8mH$, $L_m=66.33mH$, $J=0.05 kg.m^2$, $P=2$) and optimal input filter parameters ($L=1 mH$, $C=200 \mu f$).

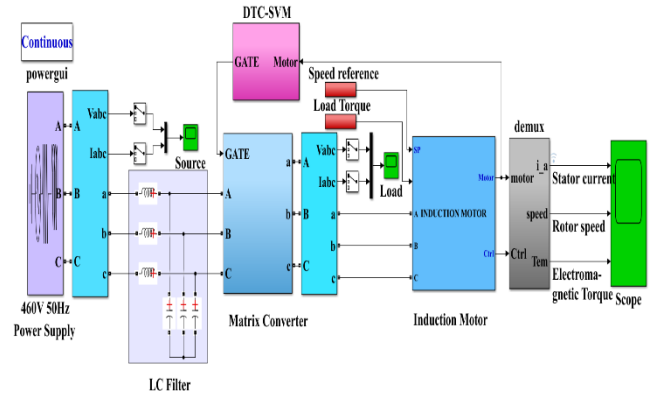

Figure 11. The simulation model for Matrix Converter-Direct Torque Control-IM (MC-DTC-IM).

Fig 12. displays the desired speed setting and the corresponding speed tracking, which align perfectly as the speed command transitions from 250 RPM to 500 -750 RPM, and subsequently decreases back to 500-250 RPM and 0 RPM.

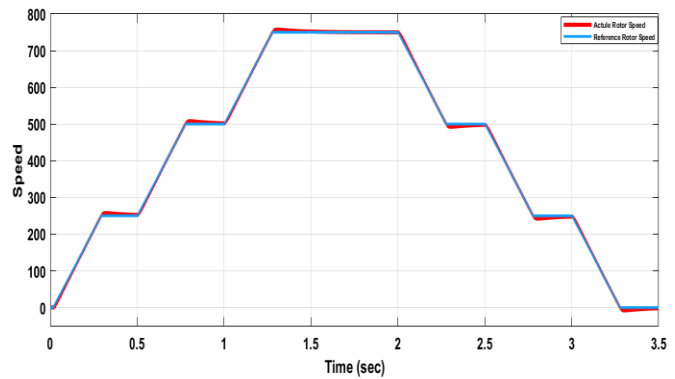

Figure 12. Speed reference in (blue) and actual speed response in (red).

Different parameters and speed references of the IM were applied, as illustrated in Fig 13.

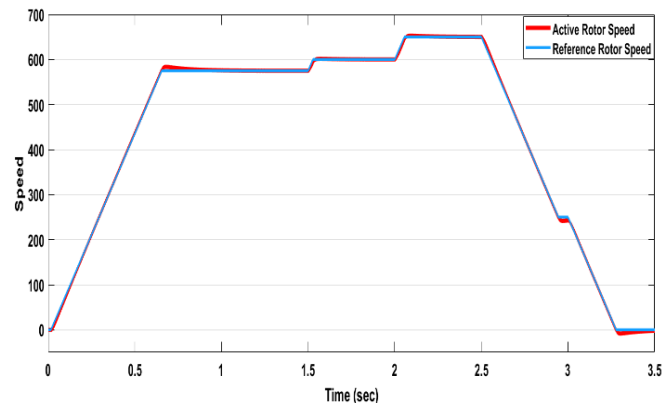

Figure 13. Speed reference in (blue) and actual speed response in (red) at speed references.

7. Conclusion

This paper delves into Matrix Converter (MC) topologies and predictive control, dissecting the inherent constraints and challenges across different configurations and spotlighting the influence of predictive control within the power electronics sphere. It discusses the equilibrium between high sampling frequency and the time required for state evaluation in multi-phase MCs, alongside their deployment in multi-drive systems incorporating two induction motors with varying load torques. The study further explores the advancements in MC technology and its burgeoning applications in domains such as renewable energy, energy storage, and microgrids, including the potential for retrofitting within existing frameworks. It accentuates recent progress in both direct and indirect MC structures, alongside modulation and control algorithms developments, scrutinizing various control strategies with a focus on Space Vector Modulation (SVM) and its evolution and performance metrics. The MC-DTC method integrates DTC with SVM to steer induction motors via MCs, with a novel switching table that ensures comprehensive control over motor demands while preserving the unity power factor. Simulation outcomes reveal enhanced input current harmonic profiles and superior low-speed functionality relative to conventional MC-DTC approaches, meriting further investigation given its considerable benefits and promising outlook.

Funding

“None”

Acknowledgments

I want to thank my supervisor, whose guidance and support made this paper. Thanks also to Tikrit University, College of Engineering, Department of Electrical Engineering.

Conflicts of Interest

The authors state no conflict of interest.

References

- [1] D. I Son, J. S. Han, J. S. Park, H. S. Lim, and G. H. Lee, “Performance improvement of DTC-SVM of PMSM with compensation for the dead time effect and power switch loss based on extended Kalman filter,” *Elect.*, vol. 12, no. 4, pp. 966, Feb. 2023, [doi:10.3390/electronics12040966](https://doi.org/10.3390/electronics12040966).
- [2] B. Charaf, L. Hocine, and M. Boubekeur, “A Novel approach for controlling with a matrix converter,” *Rev. Roma. Sci. Tech.*, vol. 68, no. 1, pp. 24=29, Abr. 2023, doi.org/10.59277/RRSTEE.2023.68.1.
- [3] D. Nandkumar, D. Shinde, and D. Shriwastava, “Implementation of DTC-controlled PMSM driven by a matrix converter,” *IJRTE Intern. Jour. of Rece. Techn. and Eng.*, vol.8, no.5, pp 4420-4424, Jan.2020, [doi:10.35940/ijrte.E6641.018520](https://doi.org/10.35940/ijrte.E6641.018520).
- [4] P. Sreehari, and M. Anka, “FLC-MPC based direct torque control for matrix converter fed induction motor drive,” *UGC Car. Gro. I Lis. Jou.*, vol.13, no.01, pp. 388-401, Feb. 2023, doi.org/11.45551/pfdgg.2023.68.1.
- [5] M. Sabour, G. Bachir, and N. Henini, “Deep learning approach for open switch fault diagnosis in matrix frequency converter,” *Przeg. Elektrotech.*, vol.96, no.1, pp. 155 – 160, Nov. 2020, [doi:10.15199/48.2020.11.32](https://doi.org/10.15199/48.2020.11.32)
- [6] O. Usoltsev, A. Tereshchenko, and A. Skorynina, “Machine Learning for Quantitative Structural Information from Infrared Spectra: The Case of Palladium Hydride,” *Smal. Meth.*, pp. 2301397, Jan. 2024, doi.org/10.1002/smt.202301397, 2023.
- [7] A. Rahnama, S. Ahmadian, and N. Vosoughi, “A novel torque ripple reduction of switched reluctance motor based on DTC-SVM method,” *IEEE Tex. Pow. and ene. confe.*, pp. 1–6, Feb. 2018, doi.org/10.1109/TPEC.2018.8312070.
- [8] S. Sudharani, and M. Nalini “Modeling of single-phase matrix converter using matlab,” *Inter. Jour. of Adva. in Engi. and Mana.*, vol. 5, no. 5, pp. 282-286, May 2023, [doi:10.35629/5252-0505282286](https://doi.org/10.35629/5252-0505282286).
- [9] L. Saribulut, and A. Ameen, “Student project-based space vector modulation technique for power electronics laboratory,” *Electr.* 12, vol. 12, no. 12, pp.2714, Jun. 2023, [doi:10.3390/electronics12122714](https://doi.org/10.3390/electronics12122714).

- [10] E. Nandhini, and A. Sivaprakasam, "A review of various control strategies based on space vector pulse width modulation for the voltage source inverter," *IETE Jou. of Resea.*, vol. 68, no. 5, pp. 3187–3201, Sep. 2022, [doi:10.1080/03772063.2020.1754935](https://doi.org/10.1080/03772063.2020.1754935).
- [11] M. Khalid, A. Mohan, and A. C. Binoj Kumar, "Performance analysis of vector controlled PMSM drive modulated with sinusoidal PWM and space vector PWM," *IEEE Intern. Pow. and Renew. En. Confe.*, pp 1-6, Oct. 2020, [doi:10.1109/IPRECON49514.2020.9315210](https://doi.org/10.1109/IPRECON49514.2020.9315210).
- [12] Y. Huang, Y. Xu, W. Zhang, and J. Zou, "Hybrid RPWM technique based on modified SVPWM to reduce the PWM acoustic noise," *IEEE Trans Power Electron*, vol. 34, no. 6, pp. 5667–5674, Jun. 2019, [doi:10.1109/TPEL.2018.2869980](https://doi.org/10.1109/TPEL.2018.2869980).
- [13] H. Benbouhenni, "ANFIS-sliding mode control of a DFIG supplied by a two-level SVPWM technique for wind energy conversion system," *Intern. Jour. of Appl. Pow. Eng.*, vol. 9, no. 1, pp. 36-47, Apr. 2020, [doi:10.11591/ijape.v9.i1.pp36-47](https://doi.org/10.11591/ijape.v9.i1.pp36-47).
- [14] T. Qanbari, B. Tousi, and M. Farhadi-Kangarlu, "A novel vector based pulse width modulation for cascaded H-bridge multilevel inverters," *Jour. of Opera. and Autom. in Pow. Engin.*, vol. 11, no. 2, pp. 113–122, Aug. 2023, [doi:10.22098/IOAPE.2023.9960.1703](https://doi.org/10.22098/IOAPE.2023.9960.1703).
- [15] G. Sieklucki, S. Sobieraj, J. Gromba, and R.E. Necula, "Analysis and Approximation of THD and Torque Ripple of Induction Motor for SVPWM Control of VSI," *Ener. Bas.*, vol. 16, no. 12, pp. 4628, Jun. 2023, [doi:10.3390/en16124628](https://doi.org/10.3390/en16124628).
- [16] U. R. Muduli, and R. K. Behera, "Virtual vector based SVPWM-DTC for five-phase two-level VSI fed induction motor drive," *Intern. Confe. on Pow. Electr. and Ene.* Jan. 2021, pp. 1-6, [doi:10.1109/ICPEE50452.2021.935875](https://doi.org/10.1109/ICPEE50452.2021.935875).
- [17] S. Pipolo, A. Formentini, A. Trentin, P. Zanchetta, M. Calvini, and M. Venturini, "A new modulation approach for matrix converter," *Intern. Confe. on Po. Electr.*, vol. 5, pp. 1021-1027, May. 2019, doi.org/10.23919/ICPE2019ECCEAsia42246.
- [18] M. Ali, A. Iqbal, and M. Khalid, "A review on recent advances in matrix converter technology: Topologies, control, applications, and prospects," *Inter. Jour. of Ene. Resea.*, vol. 2023, Aug. 2023, Art. no. 6619262, [doi:10.1155/2023/6619262](https://doi.org/10.1155/2023/6619262).
- [19] A. Manati, and A. Salam, "State space modelling and disturbance evaluation for matrix converter drives," *Univ. of Thi. Jour. for Eng. Scie.*, vol. 13, no. 1, pp 11-24, May 2023, [doi:10.31663/tqujes13.1.437\(2023\)](https://doi.org/10.31663/tqujes13.1.437(2023)).
- [20] M. Chodunaj, P. Szcześniak, and J. Kaniewski, "Mathematical modeling of current source matrix converter with venturini and SVM," *Electr.*, vol. 9, no. 4, pp. 558, Apr. 2020, [doi:10.3390/electronics9040558](https://doi.org/10.3390/electronics9040558).
- [21] E. Purwanto, and G. Basuki, "Three-phase direct matrix converter with space vector modulation for induction motor drive," *IEEE Intern. Confe. on Appl. Infor. Tech. and Innov.*, pp. 11-16, Sep. 2019, doi.org/10.1109/ICAITI48442.2019.8982139.
- [22] M. Siami, D. A. Khaburi, and J. Rodriguez, "Simplified finite control set-model predictive control for matrix converter-fed PMSM drives," *IEEE Trans. Pow. Elect.*, vol. 33, no. 3, pp. 2438–2446, Mar. 2018, [doi:10.1109/TPEL.2017.2696902](https://doi.org/10.1109/TPEL.2017.2696902).
- [23] Y. Guo, B. Yang, and C. Li "Model predictive current control of active distribution transformer with consideration of Its stability analysis based on AC-AC matrix," *IEEE Ene. Conve. Cong. and Expo.*, pp. 5417-5423, Sep. 2029, [doi:10.1109/ECCE.2019.8912942](https://doi.org/10.1109/ECCE.2019.8912942).
- [24] J. Zhang, L. Li, and DG. Dorrell, "Control and applications of direct matrix converters: A review," *Chin. Jour. of Elect.*, vol. 4, no. 2, pp. 18–27, Jun. 2018, doi.org/10.23919/CJEE.2018.8409346.
- [25] Y. Moati, K. Katia, and K. Mokhtari, "Improvement of DTC of wind energy conversion system based on DSIG using matrix converter," *Intern. Confe. on Susta. Rene. Ene. Sys. and Appl.*, vol. 4, no. 5, pp. 1–6, Dec. 2019,

- doi.org/10.1109/ICSRESA49121.2019.9182509.
- [26] J. Khyat, P. Sreehari, and M. A. Rao, "FLC-MPC based Direct Torque Control for Matrix Converter-Fed Induction Motor Drive," *UGC Car. Gro. I Lis. Jour.*, vol. 13, no. 1, pp. 388–401, Feb. 2023, [doi: 10.2366/CGI.2023.665537](https://doi.org/10.2366/CGI.2023.665537).
- [27] M. Aimrk, and M. Khalid, "AC-AC Converters," In *pow. Electr. Hand.*, Butterworth-Heinemann, 2024, ch13, pp. 437-480. doi.org/10.1016/B978-0-323-99216-4.
- [28] M. Siami, D. A. Khaburi, M. Rivera, and J. Rodríguez, "A computationally efficient lookup table based FCS-MPC for PMSM drives fed by matrix converters," *IEEE Trans. on Indu. Elect.*, vol. 64, no. 10, pp. 7645–7654, Oct. 2017, [doi: 10.1109/TIE.2017.2694392](https://doi.org/10.1109/TIE.2017.2694392).
- [29] Y. Wang, and P. Wang, "An improved bipolar-type AC-AC converter topology based on nondifferential dual-buck PWM AC choppers," *IEEE Trans. on Pow. Electr.*, vol. 36, no. 4, pp. 4052 – 4065, Apr. 2020, doi.org/10.1109/TPEL.2020.3022026.
- [30] P. Yao, and X. Jiang, "An optimal six vector switching pattern in matrix converters for reducing harmonics and switching loss," *CSEE Jour. of Pow. and Ene. Syst.*, vol. 9, no. 1, pp. 135–144, Jan. 2023, [doi: 10.17775/CSEEJPES.2019.03290](https://doi.org/10.17775/CSEEJPES.2019.03290).
- [31] M. Mennad, A. Bentaallah, Y. Djeriri, and A. Bessas, "Improved performance of a fuzzy control of double star induction motor Fed by two three-phases matrix converters," *Artif. Intelli. and Rene. Tow. an Ene. Tran.*, vol. 4, no. pp. 336-350, Dec. 2021, doi.org/10.1007/978-3-030-63846-7_33.
- [32] D. Varajão and R. E. Araújo, "Modulation methods for direct and indirect matrix converters: A review," *Electr.* vol. 10, no. 7, pp. 812, Apr. 2021, [doi: 10.3390/electronics10070812](https://doi.org/10.3390/electronics10070812).
- [33] S. Pipolo, A. Formentini, A. Trentin, P. Zanchetta, M. Calvini, and M. Venturini, "A novel matrix converter modulation with a reduced number of commutations," *IEEE Trans. Ind. Appl.*, vol. 57, no. 5, pp. 4991–5000, Sep. 2021, [doi: 10.1109/TIA.2021.3087121](https://doi.org/10.1109/TIA.2021.3087121).
- [34] A. Jamna, J. Pradeep, and V. Jamuna, "Comparative analysis of voltage controllers for a single stage AC-AC converter for aircraft ground power unit application," *Mate. Tod. Proc.*, vol. 45, no. 2, pp. 2381-2390, Jun. 2021, [doi:10.1016/j.matpr.2020.10.731](https://doi.org/10.1016/j.matpr.2020.10.731).
- [35] P. Szczepankowski, P. Wheeler, and T. Bajdecki, "Application of analytic signal and smooth interpolation in pulse width modulation for conventional matrix converters," *IEEE Trans. on Indu. Electr.*, vol. 67, no. 12, pp. 10011–10023, Dec. 2020, [doi: 10.1109/TIE.2019.2956391](https://doi.org/10.1109/TIE.2019.2956391).
- [36] R. Alammari, Z. Aleem, A. Iqbal, and S. Winberg, "Matrix converters for electric power conversion: Review of topologies and basic control techniques," *Intern. Trans. on Elec. Ene. Sys.*, vol. 29, no. 10, pp. e12063, Oct. 2019, doi.org/10.1002/2050-7038.12063.
- [37] W. Deng, X. Fu, J. Tang, W. Xie, and B. Ji, "Exploring the theoretical limit of voltage transfer ratio of matrix converter under the constraint of rotating vector," *IEEE Acc.*, vol. 9, no. 12, pp. 153727-153734, Nov. 2021, [doi:10.1109/ACCESS.2021.3127948](https://doi.org/10.1109/ACCESS.2021.3127948).
- [38] P. D. Ziogas, S. I. Khan, and M. H. Rashid, "Some improved forced commutated cyclo converter structures," *IEEE Trans. on Indu. Appl.*, vol. IA-21, no. 5, pp. 1242-1253, Sep. 1985, doi.org/10.1109/TIA.1985.349549.
- [39] M. Castillo, J. Hernández, P. Flores, V. Alvarado, and C. Yáñez, "Design of the input and output filter for a matrix converter using evolutionary techniques," *Appl. Sci.*, vol. 10, no. 10, pp. 3524, May 2020, [doi 10.3390/app10103524](https://doi.org/10.3390/app10103524).
- [40] A. Poorfakhraei, M. Narimani, and A. Emadi, "A review of modulation and control techniques for multilevel inverters in traction applications," *IEEE Acc.*, vol. 9, pp. 24187-24204, Feb. 2021, doi.org/10.1109/ACCESS.2021.3056612.
- [41] S. Khanday, O. Sekhar, and T. Mir, "Comparative study of three-phase AC/AC in-direct matrix converters: A review," *Intern. Confe. for Advan.*

- in Tech., pp. 1-6, Jan. 2022, doi.org/10.1109/ICONAT53423.2022.9726119”
- [42] M. Hussain, A. Hati, P. Chakrabarti, B. Hung, V. Bolshev, and V. Panchenko, “DSVM-based model-free predictive current control of an induction motor,” *Ener.*, vol. 16, no. 15, pp. 5657, Aug. 2023, [doi: 10.3390/en16155657](https://doi.org/10.3390/en16155657).
- [43] K. Rahman, “Matrix converter and Its probable applications.” *DC Micro. Adva. Chall. and Applic.*, vol. 8, no. 4, pp. 273-298, Jun. 2022, doi.org/10.1002/9781119777618.
- [44] M. Saravanan, A. Sathish Kumar, R. Devasaran, G. Seshadri, and S. Sivaganesan, “Performance analysis of very sparse matrix converter using indirect space vector modulation,” *Intern. Jou. of Inn. Techn. and Expl. Eng.*, vol. 9, no. 1, pp. 4756–4762, Nov. 2019, [doi: 10.35940/ijitee.A4462.119119](https://doi.org/10.35940/ijitee.A4462.119119).
- [45] P. Szczesniak, “Challenges and design requirements for industrial applications of AC/AC power converters without DC-link,” *Ene.*, vol. 12, no. 8, pp. 1581, Apr. 2019, [doi: 10.3390/en12081581](https://doi.org/10.3390/en12081581).
- [46] Q. Tran, T. Nguyen, and L. Phuong, “Simplified space-vector modulation strategy for indirect matrix converter with common-mode voltage and harmonic distortion reduction,” *IEEE Acc.*, vol. 8, pp. 218489–218498, Apr. 2020, [doi:10.1109/ACCESS.2020.3042528](https://doi.org/10.1109/ACCESS.2020.3042528).
- [47] M. Israyelu, and S. Sashidhar, “Comparison of switching patterns of SVM for a novel high gain indirect matrix converter,” *Ann. Conf. of the IEEE Ind. Electr. Soc.*, pp. 1-6, Jan. 2022, doi.org/10.1109/IECON48115.2021.959900.
- [48] M. Kazmierkowski, “Modular multilevel converters: analysis, control, and applications,” *IEEE Indu. Electr. Maga.*, vol. 14, no. 3, pp. 113-114, Sep. 2020, doi.org/10.1109/MIE.2020.3008022.
- [49] S. Vashishtha, and K. Rekha, “Modified digital space vector pulse width modulation realization on low-cost FPGA platform with optimization for 3-phase voltage source inverter,” *Intern. Jour. of Elect. and Comp. Eng.*, vol. 11, no. 4, pp. 3629–3638, Aug. 2021, [doi:10.11591/ijece.v11i4.pp3629-3638](https://doi.org/10.11591/ijece.v11i4.pp3629-3638).
- [50] M. Malla, S. K. Gudey, and S. Sudha, “Transient and steady state characteristics of induction motor drive using DTC-SVM technique for EV applications,” *IEEE Inter. Confe. on Electr. and Comp. Engin.*, pp. 403-406, Dec. 2020, [doi:10.1109/ICECE51571.2020.9393056](https://doi.org/10.1109/ICECE51571.2020.9393056).
- [51] S. Suhel, and R. Maurya, “Realization of 24-Sector SVPWM with New Switching Pattern for Six-Phase Induction Motor Drive,” *IEEE Trans. Pow. Electro*, vol. 34, no. 6, pp. 5079–5092, Jun. 2019, [doi:10.1109/TPEL.2018.2870952](https://doi.org/10.1109/TPEL.2018.2870952).
- [52] S. P. Jena, and K. Chandra, “Comparative analysis of the harmonic reduction of VSI fed induction motor using SVPWM and sinusoidal PWM,” *IEEE Inter. Confer. on Tren. in Elect. and Infor.*, pp. 1-5, May 2018, doi.org/10.1109/ICOEI.2018.8553727.
- [53] E. Nandhini, and A. Sivaprakasam, “Sinusoidal PWM vs SVPWM for NPC multilevel inverter with proportional control based neutral point voltage controller for induction motor drive,” *Jou. of Eng. Res. and Rep.*, vol. 25, no. 2, pp. 39–47, May 2023, [doi: 10.9734/jerr/2023/v25i2878](https://doi.org/10.9734/jerr/2023/v25i2878).