



Unviersty of Anbar

Anbar Journal of Engineering Science©

journal homepage: <https://ajes.uoanbar.edu.iq/>



Review on a Cooling Method for the Gas Turbine Power Plant

Hisham Saeed Hashim^a, Muna Sabah Kassim^b, Raid Abd Alwan^c

^{a,b} Department of Mechanical Engineering, Engineering College, Mustansiriyah University, Baghdad, Iraq.

^c UTM, Malaysia. Training and Power Researches office Power Researches Department Ministry of Electricity, Baghdad, Iraq

PAPER INFO

Paper history (8pt)

Received: 05/12/2022

Revised: 24/01/2023

Accepted: 17/02/2023

Keywords:

Cooling Method,
Turbine Power Plant
thermal efficiency



Copyright: ©2023 by the authors. Submitted for possible open access publication under the terms and conditions of the Creative Commons Attribution (CC BY-NC 4.0) license.

<https://creativecommons.org/licenses/by-nc/4.0/>

ABSTRACT

To increase output power and thermal efficiency, the temperature entering a gas turbine is higher than the point at which the material would melt. To protect the airfoil of a gas turbine from hot gas and, as a result, extend the blade's life, new internal and film cooling arrangements must be developed immediately. The gas turbine's output increases proportionately when the incoming air is heated. The power output of a gas turbine is determined by the amount of mass flowing through it. Because of this, electricity generation decreases on warm days due to a decrease in air density. It takes a 1% rise in air temperature to reduce power production by 1%. This research aims to discuss current strategies for cooling incoming air for gas turbines. Mechanical chillers, evaporative coolers, and fogging methods have all been examined. This study focuses primarily on the fogging inlet air cooling system. There are many ways to cool the air going into the engine, but the high-pressure intake fogging method has become more popular over the past ten years because it costs less and makes a big difference in power.

1. Introduction

Fossil-fuel-based power generation faces new challenges and opportunities due to the growing interest in renewable energy sources. Natural gas is the least polluting fossil fuel in terms of greenhouse gas (GHG) emissions. Increasing thermal efficiency could reduce GHG emissions by 40% over the next two decades [1]. Gas turbines are versatile devices that can meet a variety of energy needs. Turbine design knowledge is critical for equipment selection. Manufacturers frequently provide full-load capacity and design information for 15 °C and 101.3 kPa ISO standards. The changes in

environmental conditions affect the turbine's power generation capacity and efficiency. Studies have shown that ambient temperature affects gas turbine performance [1]. The thermal efficiency of a gas turbine is one of the most significant parameters to consider while evaluating its performance. The thermal efficiency of a gas turbine may be enhanced by raising the gas's temperature. Modern turbine engines operate at temperatures higher than 2000 K, significantly higher than the blade materials' melting points. To prevent the hot gas from inflicting damage on the blade, which would ultimately result in the blade's being destroyed [2]. A variety of cooling techniques

* Corresponding author: Hisham Saeed Hashim; mschishamsaed@gmail.com ; +9647702665586

can be used to accomplish this. The most efficient cooling systems are evaporative coolers, mechanical chillers, and absorption chillers. Ice storage is another option, which offers certain technological advantages as well as more options for system performance strategy choosing [3-5]. Electrical generator power plants are vital in rising economies. The combined cycle uses so-called combined units to produce energy from fossil fuels. The combined cycle at Shuaiba North has three gas turbines and one steam turbine. The performance of these units is crucial. The temperature of the air entering the gas turbine compressors affects unit performance, creating an absorption chiller to cool the air [6-10]. The absorption chiller may use gas turbine waste gases. To cool the input air from +45 to +15 °C, 4260 kW of heat is requested. The obtained findings suggest that utilizing the heat from gas turbine waste gases in an absorption chiller is not cost-effective, since CHP efficiency drops from 81.4% to 74.4% at +45 °C [11-18] discussed several gas turbine inlet air cooling solutions. The results of applying air cooling to three distinct gas turbines and one gas turbine in a combined cycle under residential ambient circumstances are analyzed and the method of determining the power gain produced by air cooling. Significant increases in turbine power were achieved. Operation management's primary purpose is to properly complete the life cycle of power systems while using the least amount of resources possible. [19] and [20] investigated the integration of a cooled gas turbine-based combined cycle with a (lithium bromide–water) absorption intake air-cooling method. Before leaving the waste heat recovery steam generator, the exhaust gas was used to power the cooling system. Inlet fogging has recently gained popularity as a way of boosting the power output of gas turbines and combined cycle power plants by chilling the air inlet. During hot seasons, intake air cooling is frequently used to boost power production and improve the thermal efficiency of gas turbines. In some circumstances, evaporative cooling of the air stream in the intake duct is a cost-effective technique to provide input cooling [21-26].

2. Cooling Section Design for Fogging Gas Turbine

The plant's performance was improved during the summer months by installing an input air conditioning section. The compression

refrigeration approach was found to be ineffective in this case. There is no way to avoid using electricity during the day, when it is the most expensive, without TES. Without TES, a compression refrigeration system's efficiency would be greatly affected by part-load operating conditions. Instead, the summertime investment costs and complexity would be higher for a TES based on ice than for a water-based system [27-30]. Regarding the absorption system, [31] evaluated single- and two-stage designs. Two-stage absorbers have a COP of 1.2, almost double that of single-stage absorbers, which normally have a COP of 0.7, (ASHRAE, 1989). On the other hand, two-stage units utilize steam at 8 bar, whereas single-stage machines require a higher steam flow rate but lower pressure (2.5 bar). Because the steam turbine is drained in both cases, the cost of the power not produced must be factored in. The electricity not generated by the two-stage absorber (61.5 kWh/MBtu) is 58.3 kWh per GJ of cooling thermal load, but by the single-stage absorber (82.0 kWh/MBtu) is 77.8 kWh. This results in an increase of 32% in power loss. The cooling water required by the unit is another point of comparison. More than twice as much water flows through the single-stage absorber than via two-stage absorbers of equal power [27-34] Consequently, the following ideas were thought of:

- Case A: Absorption chiller with two stages.
- Case B: Absorption chiller with a single stage.
- Case C: Cooling by evaporation.

2.1. Fogging of Gas Turbine Inlets

High-pressure atomizing nozzles transform demineralized water into fog droplets (2000 psi). Air in the intake duct is cooled by small (5–20 micron) droplets, boosting the mass flow rate. Meher-Homji and Mee have studied the thermodynamics and practicalities of inlet fogging [35]. This approach achieves saturation levels and wet-bulb temperatures around 100% evaporation efficiency at the gas turbine intake. Fog intercooling releases more fog into the compressor; high-pressure intake fogging may help provide intercooling. This is called "overspray" or "wet compression," giving the engine more power. A decrease in compressor work input is used to achieve the power gain. The surplus fog fed into the compressor intake is typically between 0.5 and 2% of the gas turbine's incoming air mass flow. Table (1) shows that a 50 Hz heavy-duty gas turbine (GE

9171E) was studied for performance. This data table shows how inlet fogging affects the fluctuation of major gas turbine characteristics. The increase in air mass flow rate produced by the 13°C reduction in wet-bulb temperature increases compressor effort. With a 10 MW increase in gas turbine net output, the increase in turbine section work output is proportional. Table 1 showed overspray fogging reduces the compressor's work input by intercooling the fog. Input fogging (evaporative and overspray) increases fuel flow while decreasing compressor output temperature increases heat rate [35].

Table 1. Analysis of gas turbine performance in the presence of base and inlet fogging

Parameter	Base case	Fog to saturation	Overspray OS=1 %	Overspray OS=2 %
Ambient temperature, °C	43	43	43	43
Compressor inlet temperature, °C	43	30	30	30
Compressor discharge temperature, °C	386	371	330	293
Compressor discharge pressure, bar	10.93	11.53	11.69	11.84
Overall pressure ration	10.90	11.53	11.60	11.80
Turbine inlet temperature, °C	1122	1121	1120	1118
Exhaust gas temperature, °C	567	557	555	553
Air mass flow rate at compressor inlet, kg/sec	357.63	374.59	374.59	374.59
Total mass flow rate at	357.63	376.61	380.37	384.14

compressor inlet, kg/sec				
Fuel flow rate, kg/sec	6.304	6.784	6.234	7.677
Compressor work input, kW	128.027	134.678	129.305	125.073
Total turbine work output, kW	230.599	247.877	253.003	258.061
Gas turbine cycle efficiency, %	28.67	29.43	30.14	30.58
Turbine network output ratio (W.N)	0.45	0.46	0.49	0.52
Compressor work output ratio (W.C)	0.56	0.54	0.51	0.48
Fog water flow rate, kg/sec	0	2.023	5.789	9.555
Gas turbine net output, kW	100.381	110.868	121.216	130.363
Heat rate, kWh	11.315	11.024	10.766	10.609

2.2. Technology for Inlet Fogging

Direct input fogging is a cooling technology that uses unique atomizing nozzles that operate at 138 bar to transform demineralized water into a fog (2000 psi). Meher-Homji and Mee describe the thermodynamics and practical aspects of fogging [33-36]. When the fog evaporates in the gas turbine's air input duct, it offers to cool. This technology achieves near-perfect efficiency in achieving 100 percent relative humidity at the gas turbine input, resulting in the lowest temperature (wet bulb temperature) feasible without refrigeration. Direct high-pressure intake fogging can also be used to intercool the compressor, increasing power output [37]. There is no

consideration of fog intercooling; only evaporative fogging is examined. Bhargava and Meher-Homji [38] have published a comprehensive parametric analysis of gas turbine reactions to fogging. Ingistov [39] discusses a fog intercooling application for heavy-duty gas turbines. Figure 1 depicts an image of a typical high-pressure-fogging skid.



Figure 1. Typical fogging skid with high pressure. Here are the feed lines from the high-pressure pumps to the intake system [39]

High-pressure reciprocating pumps supply demineralized water to fogging nozzles in the intake air duct. As shown in Figure 2, each high-pressure pump has fog nozzles. Pumps can be used to regulate the amount of cooling water.. Many pump combinations and pump displacements can be used to cool [40].

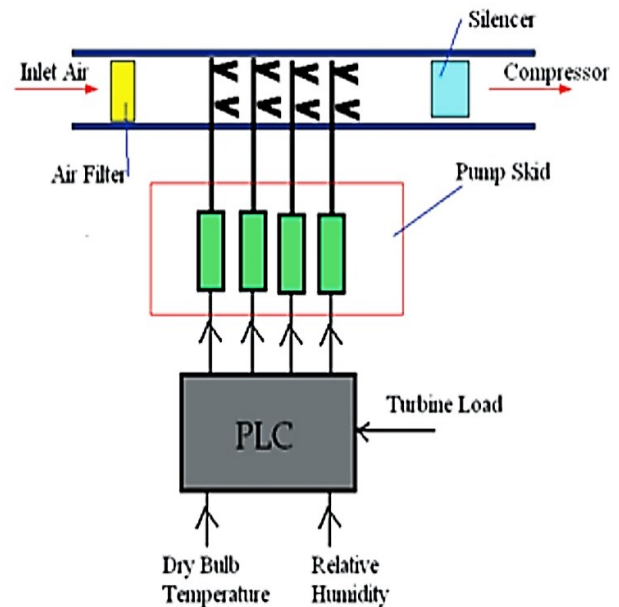

Figure 2. Gas Turbine Inlet Fogging Control System [40]

For intake fogging, high-pressure reciprocating pumps provide demineralized water to an array of fogging nozzles. Micron-sized droplets evaporate and chill the entering air to wet bulb temperatures. Figure 3 shows a nozzle array fogging an input duct for a large-frame gas turbine. Figure 4 depicts a typical from a single fog nozzle.

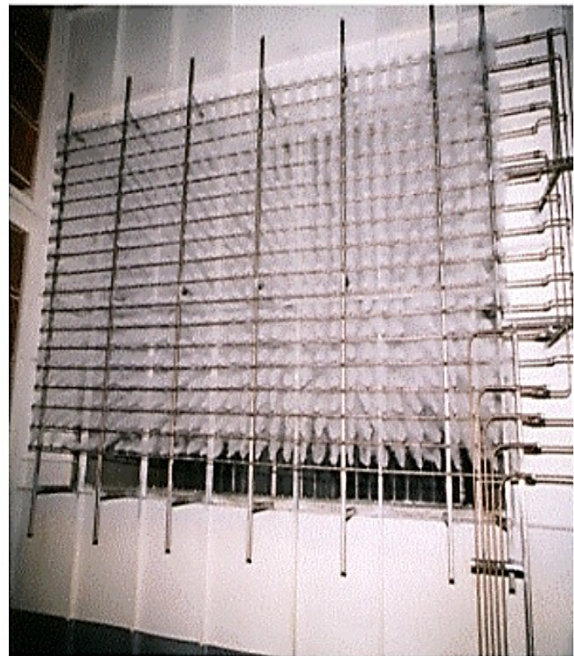

Figure 3. High pressure fogging skid for a heavy-duty gas turbine (in operation) [40]



Figure 4. Fog plume typical of a single fog nozzle [41]

2.3. Fogging Arrangement

A typical fogging system includes:

- 1) Pumps with high pressure installed on a skid.
- 2) A control system based on a programmable logic controller (PLC) and a temperature and humidity sensor.
- 3) Installation of several nozzles in the air intake duct. Figure 5 depicts the standard wet compression gas turbine (WCG) and regenerative WCG cycles.

3. Generation of Fog

Fog is made by putting demineralized water under high pressure (70 to 200 bar) through a set of specially designed fog nozzles. The nozzles are made up of a small orifice. A highly designed impaction pin fractures the water jet into billions of tiny fog particles. The amount of exposed water determines how quickly a droplet evaporates [41].

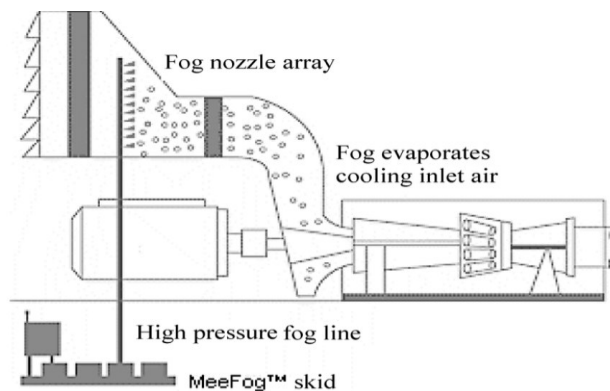

Figure 5. Typical fogging gas turbine [41]

Figure 6 shows the fogging system. The WCG system pumps water into the compressor intake, compressing the mixture from states 1 to 2. The temperature of the mixture drops as water evaporates during compression. State 3: The fuel is added to the combustion chamber, and the flame reaches adiabatic temperature while the pressure stays the same. When the hot gas reaches state 4, it spreads out and is pushed out of the turbine. The compression causes water to evaporate from the mixture, lowering its temperature. When the fuel is supplied, the flame achieves adiabatic temperature, and the pressure remains the same in this third stage. States 3 and 4 are reached by expanding the hot gas, at which point the turbine releases it. The following are some of the work's key assumptions:

- The combustion is completely adiabatic.
- The air's ratio of N_2 to O_2 is 3.76 moles per mole.
- The fuel refers to a composition-neutral hydrocarbon (C_aH_b). However, the calculations are for methane (CH_4).
- Consistent polytropic efficiencies describe compressor and turbine performance.
- Basing on gas temperatures, the regenerator efficacy is considered to be constant.

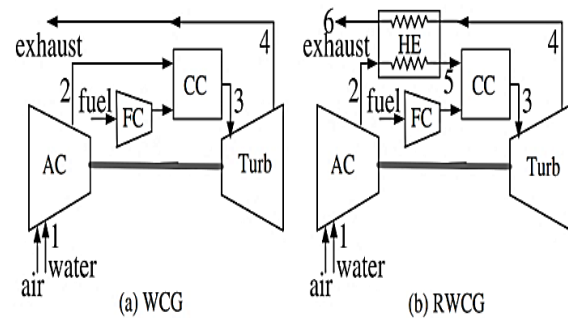

Figure 5. A graphical representation of the wet-compression gas turbine (WCG) and regenerative wet-compression gas turbine (RWCG) systems [40]

3.1 Proposed Cooling Scheme for Fogging Gas Turbine

As previously stated, there are numerous ways to cool the compressor's incoming air. Because Mashhad has a low relative humidity and a large temperature difference between dry and wet bulbs, evaporative cooling or fogging systems work well here. Evaporative and fogging systems work on the same principle, albeit fog inlet cooling is more effective [42]. As a result, a fogging system like the

one depicted in Figure 7 is proposed, with microns (m) having a higher evaporation rate than bigger sizes. The fogging system incorporates a modulated control mechanism, allowing the water spray to be delivered gradually. This continuous measurement procedure monitors and controls the pump and valve actuators, completely automating the modulation [43][44]. A high-pressure positive displacement pump sends treated water to the nozzles, where the fog is mixed with air to ensure it is properly saturated, as depicted in Figure 8. Immediately following the air filter elements, fogging nozzles spray cool air into the compressor [44]. This may result in lower air temperatures because the fogging system is meant to be 100% efficient. The control procedure is set up such that the air temperature does not fall below 5 °C. It's to prevent the compressor from locking up in the early phases. According to Mashhad meteorological data, the design point is set at 35 oC and 11% humidity. The following formula is used to calculate the needed water flow rate:

$$w_{Dry,DP} = 0.0035 \text{ kgw/kg}$$

$$w_{wet,DP} = 0.0135 \text{ kgw/kg}$$

$$= \dot{m}_{w,DP} = (w_{wet,DP} - w_{Dry,DP})\dot{m}_{air,DP} = 11.034 \text{ m}^3/\text{h} \quad (1)$$

In which case $\dot{m}_{air,DP}$ may be calculated using Eq 1. Because 1.5 m³ of raw water is required to produce 1 m³ de-mineralized water, each unit should have a raw water supply of 16.551 m³/h [43].

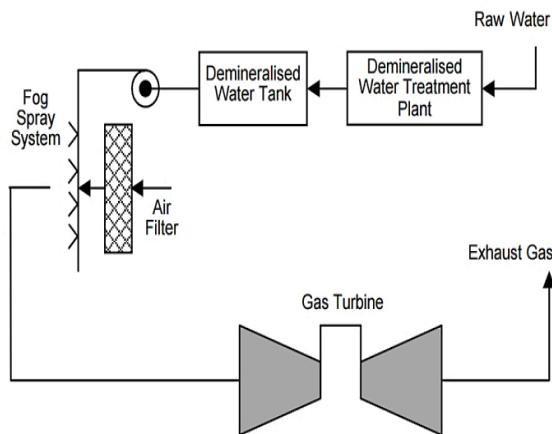

Figure 6. Fogging system [42]

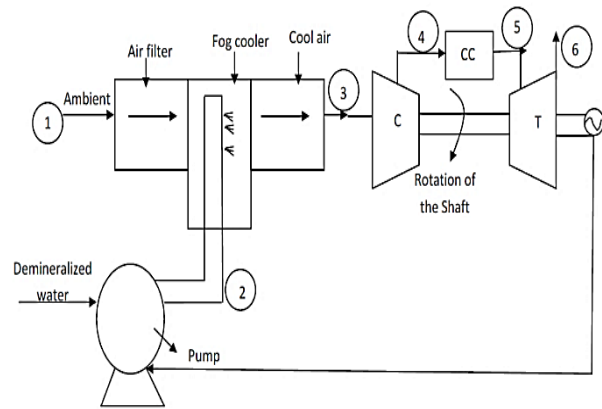

Figure 7. The Model's Schematic Diagram [43]

3.1. Thermodynamic Analysis of Gas Turbine Fogging System

A fogging nozzle receives demineralized water from a high-pressure reciprocating pump. This makes sure that the air is completely saturated. Cooling is provided by the evaporation of fog in the gas turbine's intake duct. In the compressor stages of a gas turbine engine, the air coming in gets hotter and more pressurized while its volume goes down. The lowest temperature achievable without refrigeration is 100 percent relative humidity at the compressor inlet (wet bulb temperature). Based on these assumptions, a gas turbine power plant was modelled [45], [46]. There are adiabatic limits for each component.

- The air and the byproducts of combustion are in perfect condition.
- The energy's kinetic and potential parts are not taken into account.
- There are 25.69 °C and 101.30 kPa ambient temperatures.

Figure 8, depicts a basic fogging cooling system with several steps involved in the operation. To avoid compressor blade damage when working with water, the following recommendations must be followed [47]. The fogging system's water quality must be controlled.

- There should be a pH range of 6 to 8 in the water.
- The total dissolved solids concentration must be less than 5 ppm.
- There should be less than 0.1 ppm of sodium, calcium, and silica.

- Concentrations of chloride and sulphate less than 0.5 ppm.

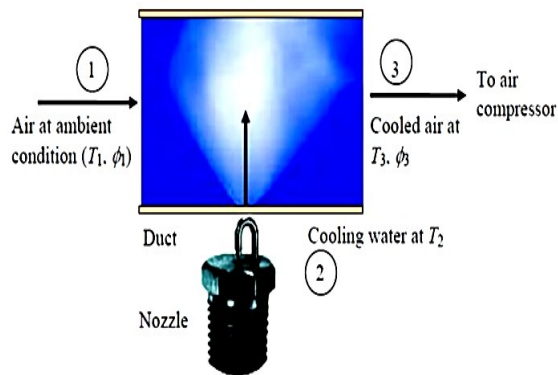

Figure 8. Cooling system with fogging [45]

4. The Use of a Sole Absorption Chiller

4.1. Thermodynamic Model (required cooling capacity and volume of condensed water)

The capacity required by an absorption chiller to lower the outside air temperature to ISO is determined in this section. It was tried to estimate the number (capacity) of absorption chillers required for each climate from a commercial brochure. Also examined is condensed water, which may be utilized in an M-cycle integrated system. According to [48], the design point for a gas turbine used as the calculation criterion in the study published by [48] is 15 °C and 100 percent relative humidity. Lower temperatures, on the other hand, result in higher power production. Nonetheless, it should be remembered that the inlet air temperature can be lowered till ice forms.

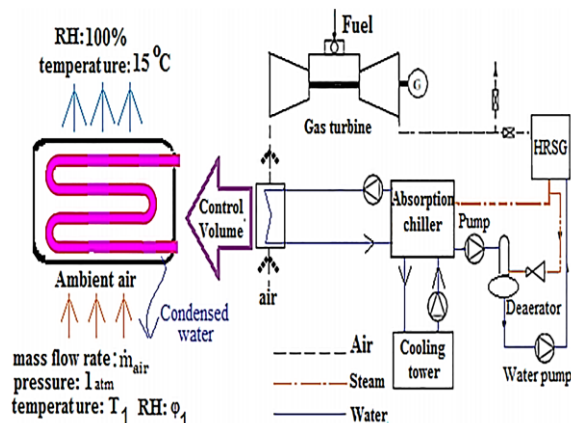

Figure 9. Airflow on the evaporator coil of an absorption chiller [45]

Ice formation is more common at 5 °C and might be another interesting factor [49-51]. The use of an absorption chiller on a gas turbine illustrates in Figure 9. The required cooling capacity is estimated when the incoming airflow reaches 15 °C with 100% relative humidity. Air fluid in a given control volume, represented in Figure 10, is subject to the first law of thermodynamics and mass conservation.

5. Thermodynamics and System Description Modeling of a Gas Turbine with Evaporative Cooling at the Inlet

Figure 10 depicts a schematic of a gas turbine with steam injection and evaporative cooling at the compressor input. An evaporative cooler draws ambient air into the compressor and cools it before entering it. The fuel is ignited by compressed air entering the combustion chamber. The steam generated by the HRSG is pushed into the combustion chamber to boost output at a given turbine intake temperature, while the rest is utilized to cool the gas turbine blades and maintain the higher turbine inlet temperature. Natural gas is used as a fuel, with the air entering the compressor assumed to be an ideal gas. Calculations of pressure loss and coolant injection into turbine blades can be made using the formulas in Table 1, [46]. Mathematical modelling of steam injection gas turbine-based power plants is based on mass and energy balance. The researchers at Lia et al. [47] looked at how two-stage series evaporation may be used with non-isothermal phase shifts of non-azeotropic mixtures to efficiently increase heat recovery.

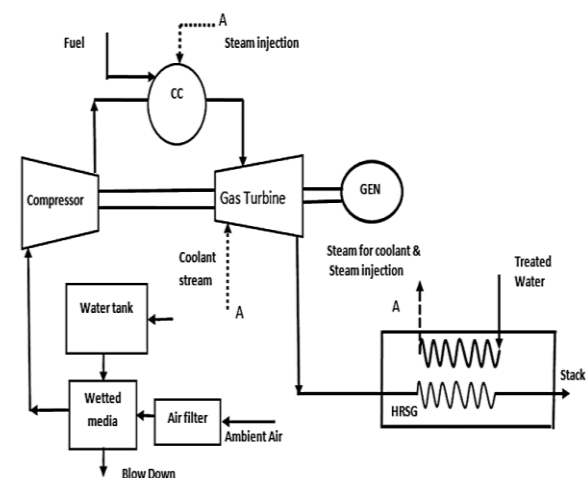

Figure 10. Schematic of a steam-injected gas turbine with evaporative intake air cooling [47]

6. Conclusions

A gas turbine engine's turbine is the most important component, and its performance considerably influences the engine's overall performance. Thermal efficiency and output power are the two most important factors to consider when assessing a gas turbine's performance. Turbine cooling structure optimization has recently gained popularity as a way to improve cooling performance. This study analyses optimization work on cooling structures in gas turbines to highlight the current state and provide further viewpoints. It was found that when the ambient temperature rises from +15 to +45 °C, the gas turbine power output drops from 28.1 MW to 24.1 MW, and the electrical efficiency drops from 34.2 to 32.0 percent. An absorption chiller was proposed to cool the air. The fogging cooling system works best when the temperature is below 30°C, and the relative humidity is below 60%. Inlet air cooling system for gas turbines using EAHE and Fogging Inlet Air Cooling System. When paired with overspray, intake fogging can reduce compressor work by up to 12%. This is because of compressor intercooling, when sprayed, water evaporates, cooling the compressed air and improving compressor performance.

In contrast, because of the higher air mass flow rate, inlet fogging without overspray increases the compressor's workload. A gas turbine with a two-stage evaporative TIAC system produces 20% more summer power than a turbine without one. These TIAC systems boost summer electricity output by 16.8%, 19.3%, and 19.3%, respectively.

References

- [1] M. De, L.C. Lanfranchi, Benefits of Compressor Inlet Air Cooling for Gas Turbine Cogeneration Plants, 1996.
- [2] G. Zhang, R. Zhu, G. Xie, S. Li, B. Sundén, Optimization of cooling structures in gas turbines: A review, *Chinese J. Aeronaut.* 35 (2022) 18–46. <https://doi.org/10.1016/j.cja.2021.08.029>.
- [3] R. Garetta, L.M. Romeo, A. Gil, Methodology for the economic evaluation of gas turbine air cooling systems in combined cycle applications, *Energy.* 29 (2004) 1805–1818. <https://doi.org/10.1016/j.energy.2004.03.040>.
- [4] G. Comodi, M. Renzi, F. Caresana, L. Pelagalli, Limiting the Effect of Ambient Temperature on Micro Gas Turbines (MGTs) Performance Through Inlet Air Cooling (IAC) Techniques: An Experimental Comparison between Fogging and Direct Expansion, *Energy Procedia.* 75 (2015) 1172–1177. <https://doi.org/10.1016/j.egypro.2015.07.561>.
- [5] M.M. Alhazmy, Y.S.H. Najjar, Augmentation of gas turbine performance using air coolers, *Appl. Therm. Eng.* 24 (2004) 415–429. <https://doi.org/10.1016/j.applthermaleng.2003.09.006>.
- [6] M.M. Alhazmy, R.K. Jassim, G.M. Zaki, Performance enhancement of gas turbines by inlet air-cooling in hot and humid climates, *Int. J. Energy Res.* 30 (2006) 777–797. <https://doi.org/10.1002/er.1184>.
- [7] O.R. AL-Hamdan, A.A. Saker, Studying the Role Played by Evaporative Cooler on the Performance of GE Gas Turbine Existed in Shuaiba North Electric Generator Power Plant, *Energy Power Eng.* 05 (2013) 391–400. <https://doi.org/10.4236/epe.2013.56041>.
- [8] E. Kakaras, A. Doukelis, A. Prelipceanu, S. Karellas, Inlet air cooling methods for gas turbine based power plants, *J. Eng. Gas Turbines Power.* 128 (2006) 312–317. <https://doi.org/10.1115/1.2131888>.
- [9] Q.M. Jaber, J.O. Jaber, M.A. Khawaldah, Assessment of Power Augmentation from Gas Turbine Power Plants Using Different Inlet Air Cooling Systems, 2007.
- [10] E. Matjanov, Gas turbine efficiency enhancement using absorption chiller. Case study for Tashkent CHP, *Energy.* 192 (2020). <https://doi.org/10.1016/j.energy.2019.116625>.
- [11] E. Pyzik, S. Jarzebowski, A. Miller, Impact of inlet air cooling on gas turbine performance, *J. Power Technol.* 92 (2012) 249–257.
- [12] Y. Al-sinaiyah, S. Arabia, D. Technology, Thermo-Economics Analysis Of Gas Turbines Power Plants With Cooled Air Intake, (2010) 26–42.
- [13] A.A. El-Shazly, M. Elhelw, M.M. Sorour, W.M. El-Maghlany, Gas turbine performance enhancement via utilizing different integrated turbine inlet cooling techniques, *Alexandria Eng. J.* 55 (2016) 1903–1914. <https://doi.org/10.1016/j.aej.2016.07.036>.
- [14] R. Radchenko, A. Radchenko, S. Serbin, S. Kantor, B. Portnoi, Gas turbine unite inlet air cooling by using an excessive refrigeration capacity of absorption-ejector chiller in booster air cooler; Gas turbine unite inlet air cooling by using an excessive refrigeration capacity of absorption-ejector chiller in booster, (n.d.).

- <https://doi.org/10.1051/e3sconf/2018>.
- [15] T.K. Ibrahim, M.K. Mohammed, O.I. Awad, R. Mamat, M.K. Abdolbaqi, Thermal and Economic Analysis of Gas Turbine Using Inlet Air Cooling System, *MATEC Web Conf.* 225 (2018) 1–10. <https://doi.org/10.1051/mateconf/201822501020>.
- [16] A. Radchenko, E. Trushliakov, K. Kosowski, D. Mikielewicz, M. Radchenko, Innovative turbine intake air cooling systems and their rational designing, *Energies*. 13 (2020). <https://doi.org/10.3390/en13236201>.
- [17] M.R. Majdi Yazdi, F. Ommi, M.A. Ehyaei, M.A. Rosen, Comparison of gas turbine inlet air cooling systems for several climates in Iran using energy, exergy, economic, and environmental (4E) analyses, *Energy Convers. Manag.* 216 (2020) 112944. <https://doi.org/10.1016/j.enconman.2020.112944>.
- [18] A.M. Abubaker, A.D. Ahmad, B.B. Singh, N.K. Akafuah, K. Saito, Multi-objective linear-regression-based optimization of a hybrid solar-gas turbine combined cycle with absorption inlet-air cooling unit, *Energy Convers. Manag.* 240 (2021) 114266. <https://doi.org/10.1016/j.enconman.2021.114266>.
- [19] M.F. Elberry, A.A. Elsayed, M.A. Teamah, A.A. Abdel-Rahman, A.F. Elsafty, Performance improvement of power plants using absorption cooling system, *Alexandria Eng. J.* 57 (2018) 2679–2686. <https://doi.org/10.1016/j.aej.2017.10.004>.
- [20] M. Salehi, H. Eivazi, M. Tahani, M. Masdari, Analysis and prediction of gas turbine performance with evaporative cooling processes by developing a stage stacking algorithm, *J. Clean. Prod.* 277 (2020) 122666. <https://doi.org/10.1016/j.jclepro.2020.122666>.
- [21] M. Renzi, F. Caresana, L. Pelagalli, G. Comodi, Enhancing micro gas turbine performance through fogging technique: Experimental analysis, *Appl. Energy*. 135 (2014) 165–173. <https://doi.org/10.1016/j.apenergy.2014.08.084>.
- [22] S. Sanaye, M. Tahani, Analysis of gas turbine operating parameters with inlet fogging and wet compression processes, *Appl. Therm. Eng.* 30 (2010) 234–244. doi.org/10.1016/j.applthermaleng.2009.08.011.
- [23] K.H. Kim, H.J. Ko, K. Kim, H. Perez-Blanco, Analysis of water droplet evaporation in a gas turbine inlet fogging process, *Appl. Therm. Eng.* 33–34 (2012) 62–69. <https://doi.org/10.1016/j.applthermaleng.2011.09.012>.
- [24] M.A. Ehyaei, A. Mozafari, M.H. Alibiglou, Exergy, economic & environmental (3E) analysis of inlet fogging for gas turbine power plant, *Energy*. 36 (2011) 6851–6861. <https://doi.org/10.1016/j.energy.2011.10.011>.
- [25] H. Athari, S. Soltani, A. Bölükbaşı, M.A. Rosen, T. Morosuk, Comparative exergoeconomic analyses of the integration of biomass gasification and a gas turbine power plant with and without fogging inlet cooling, *Renew. Energy*. 76 (2015) 394–400. <https://doi.org/10.1016/j.renene.2014.11.064>.
- [26] M. Mostafa, Y.A. Eldrainy, M.M. EL-Kassaby, A comprehensive study of simple and recuperative gas turbine cycles with inlet fogging and overspray, *Therm. Sci. Eng. Prog.* 8 (2018) 318–326. <https://doi.org/10.1016/j.tsep.2018.09.006>.
- [27] O. Zeitoun, Two-stage evaporative inlet air gas turbine cooling, *Energies*. 14 (2021). <https://doi.org/10.3390/en14051382>.
- [28] S.O. Oyedepo, O. Kilanko, Thermodynamic analysis of a gas turbine power plant modeled with an evaporative cooler, *Int. J. Thermodyn.* 17 (2014) 14–20. <https://doi.org/10.5541/ijot.480>.
- [29] T. Srinivas, D. Vignesh, Performance enhancement of GT-ST power plant with inlet air cooling using lithium bromide/water vapour absorption refrigeration system Performance enhancement of GT-ST power plant with inlet air cooling, 2012.
- [30] D.A. Pinilla Fernandez, B. Foliaco, R.V. Padilla, A. Bula, A. Gonzalez-Quiroga, High ambient temperature effects on the performance of a gas turbine-based cogeneration system with supplementary fire in a tropical climate, *Case Stud. Therm. Eng.* 26 (2021) 101206. <https://doi.org/10.1016/j.csite.2021.101206>.
- [31] A. De Pascale, F. Melino, M. Morini, Analysis of inlet air cooling for IGCC power augmentation, *Energy Procedia*. 45 (2014) 1265–1274. <https://doi.org/10.1016/j.egypro.2014.01.132>.
- [32] M. Ghanaatpisheh, M. Pakaein, Optimization and increase production and efficiency of gas turbines GE-F9 using Media evaporative cooler in fars combined cycle power plant, *30th Power Syst. Conf. PSC 2015*. 8 (2017) 241–247. <https://doi.org/10.1109/IPSC.2015.7827755>.

- [33] R. Bhargava, C.B. Meher-Homji, Parametric analysis of existing gas turbines with inlet evaporative and overspray fogging, *J. Eng. Gas Turbines Power.* 127 (2005) 145–158. <https://doi.org/10.1115/1.1712980>.
- [34] W.J. Stannard, By and by, *Notes Queries.* s2-VI (1858) 323–324. <https://doi.org/10.1093/nq/s2-VI.147.323-a>.
- [35] C.B. Meher-homji, *Inlet Fogging Of Gas Turbine Engines Part A: Theory , Psychrometrics And Fog Generation ., Ratio.* (2000).
- [36] S. Ingistov, FOG system performance in power augmentation of heavy duty power generating gas turbins model 7EA, *Proc. ASME Turbo Expo.* 3 (2000) 1–11. <https://doi.org/10.1115/2000-GT-0305>.
- [37] Z. Domachowski, M. Dzida, Inlet Air Fogging of Marine Gas Turbine in Power Output Loss Compensation, *Polish Marit. Res.* 22 (2015) 53–58. <https://doi.org/10.1515/pomr-2015-0071>.
- [38] K.Y. Al-Salman, Q.A. Rishack, S.J. Al-Mousawi, *Parametric Study Of Gas Turbine Cycle With Fogging System*, 2007.
- [39] K.H. Kim, H. Perez-Blanco, Potential of regenerative gas-turbine systems with high fogging compression, *Appl. Energy.* 84 (2007) 16–28. <https://doi.org/10.1016/j.apenergy.2006.04.008>.
- [40] Presented by Heavy Duty GT - Effects of Ambient Temp, Lithium. (n.d.).
- [41] E. Ebrahimmnia-Bajestan, V. Etminan, M. Moghiman, M. Boghrati, M. Moghiman, E.E. Bajestan, *Performance Improvement Of Simple Cycle Gas Turbine By Using Fogging System As Intake Air Cooling System Production of Biodiesel (Lab/Semi Industrial) View project Nanofluid Today View project Performance Improvement Of Simple Cycle Gas Turbine By Using Fog.,* 2007.
- [42] S.S.M. Tehrani, M.S. Avval, N. Alvandifar, H. Rabiei, Technical and economic evaluation of gas turbine inlet air cooling in a combined cycle power plant, 2011 *Proc. 3rd Conf. Therm. Power Plants, CTPP 2011.* (2011).
- [43] C. Deng, A.T. Al-Sammaraie, T.K. Ibrahim, E. Kosari, F. Basrawi, F.B. Ismail, A.N. Abdalla, Air cooling techniques and corresponding impacts on combined cycle power plant (CCPP) performance: A review, *Int. J. Refrig.* 120 (2020) 161–177. <https://doi.org/10.1016/j.ijrefrig.2020.08.008>.
- [44] M.A. Ehyaei, M. Tahani, P. Ahmadi, M. Esfandiari, Optimization of fog inlet air cooling system for combined cycle power plants using genetic algorithm, *Appl. Therm. Eng.* 76 (2015) 449–461. <https://doi.org/10.1016/j.applthermaleng.2014.11.032>.
- [45] index@www.simonsgreenenergy.com.au, (n.d.).
- [46] A.K. Shukla, O. Singh, Performance evaluation of steam injected gas turbine based power plant with inlet evaporative cooling, *Appl. Therm. Eng.* 102 (2016) 454–464. <https://doi.org/10.1016/j.applthermaleng.2016.03.136>.
- [47] T. Li, J. Liu, J. Wang, N. Meng, J. Zhu, Combination of two-stage series evaporation with non-isothermal phase change of organic Rankine cycle to enhance flue gas heat recovery from gas turbine, *Energy Convers. Manag.* 185 (2019) 330–338. <https://doi.org/10.1016/j.enconman.2019.02.006>.
- [48] S. Boonnasa, P. Namprakai, T. Muangnapoh, Performance improvement of the combined cycle power plant by intake air cooling using an absorption chiller, *Energy.* 31 (2006) 2036–2046. <https://doi.org/10.1016/j.energy.2005.09.010>.
- [49] M. Tahmasebzadehbaie, S. Najafi Nobar, M. Derahaki, Thermodynamic analysis of the NGL plant in a sample gas refinery and problem solving by designing an absorption chiller, *Appl. Therm. Eng.* 159 (2019) 113963. <https://doi.org/10.1016/j.applthermaleng.2019.113963>.
- [50] H.A. El-Sattar, S. Kamel, D. Vera, F. Jurado, Tri-generation biomass system based on externally fired gas turbine, organic rankine cycle and absorption chiller, *J. Clean. Prod.* 260 (2020) 121068. <https://doi.org/10.1016/j.jclepro.2020.121068>.
- [51] B. Li, S. sen Wang, K. Wang, L. Song, Thermo-economic analysis of a combined cooling, heating and power system based on carbon dioxide power cycle and absorption chiller for waste heat recovery of gas turbine, *Energy Convers. Manag.* 224 (2020). <https://doi.org/10.1016/j.enconman.2020.113372>.