



Unviersty of Anbar

Anbar Journal Of Engineering Science©

journal homepage: <http://www.uoanbar.edu.iq/Evaluate/>



Kinematic Workspace Modelling of Two Links Robotic Manipulator

Sara SerwerYouns^a, Nazhad Ahmad Hussein^b, Dler Salih Hasan^c

^aMechanical& Mechatronics Department, Salahaddin University-Engineering College, Erbil, 440000, Iraq

^bMechanical& Mechatronics Department, Salahaddin University-Engineering College, Erbil, 440000, Iraq

^cComputer Science Department, Salahaddin University-Science College, Erbil, 440000, Iraq

PAPER INFO

Paper history:

Received

Received in revised form

Accepted

Keywords:

Workspace, Manipulator

kinematics, Arm Robot, MATLAB.

ABSTRACT

The purpose of this paper is to present a new method to establish a kinematic model for different manipulators, whose can be simulate the move in a two-dimensional workspace. The model is applied and implemented to four robot arm manipulators with a different DOF. The first step of modelling a robot is establishing its mathematical model parameters. It requires assigning proper length and angle for each link and creation rotational matrices. Simulation based on Matlab software was implemented for finding their workspace.

1. Introduction

Robot workspace is the set of positions robot can be reach. Workspace is one of most useful measures for the evaluation of robot. It's usually defined as the reachable space of the end effector in Cartesian coordinate system. However; it can be defined in joint coordinate system in terms of joint motions B_i, Z_i and S_i. Lang (2009). Obtaining any manipulator's workspace is one of the most basic steps in manipulator design. The workspace of the end-effector of a serial or parallel 6 degree-of-freedom manipulator includes three quantities representing position and three quantities representing orientation of end-effector. The manipulator's total workspace is described by taking the position and orientation workspace together. Chaudhury, A. N. (2017) In order to use robotic manipulators in real-life applications, the first step is to obtain the accurate kinematic model. The geometric workspace is an important feature of a manipulator since a small workspace can limit the possible applications of a given manipulator design. Ricard and Gosselin (1998) clarified one method for determining complex planar manipulators workspace,

the method is focused on using joint limits to attain formulas that describe limiting curves. These limiting curves are then divided at their mutual intersections and validated. The resulting sets of curve parts form the workspace envelope. The algorithm is entirely general and can be implemented to any serial, parallel or hybrid three-degree with or without joint limits planar manipulator. Goyal et al. (2010) determined the workspace of robot by using an analytical method, Denavit-Hartenberg representation was used for modeling serial kinematic chains. This method is based on analytical criteria to determine the individual behavior of the mechanism. The singularities are calculated by manipulating the Jacobian of the robot under the condition of row rank deficiency. These singularities were plotted in Matlab to produce all the surfaces enveloping the workspace of the Robot. This method has been used for treating practical examples of RV-M1 MITSUBUSHI ROBOT and 3 DOF spatial manipulator. Cao et al (2009) has been used an integrated Method based on numerical calculation and solid modeling software to

* Corresponding author. : Sara SerwerYouns ; sara.youns@gmail.com ; +9647704567812

produce 3D robot workspace. Then, the 3D shape and volume of robot workspace are generated by commercial software Unigraphics. Snyman and Plessis (2000) has been presented an optimization approach to computing the boundaries of the workspaces of planar manipulators. This numerical method comprises of discovering an appropriate point of radiation in the output coordinate space and then determining the sites of the junction of a separate pencil of rays emanating from the point of radiation with the border of the available domain. Ceccarelli, M. (1995) has been proposed a new synthesis algorithm for general three-revolute open chain manipulators making use of an algebraic formulation for the workspace boundary. This algebraic form of a synthesis model is used to formulate design equations and to display the number and the type of the multiple solutions. Bi, Z. and S. Lang (2009) have presented a forward kinematic model for identifying the workspace of tripod machine tool. The joint motions are used to compute the workspace. (Dash, Chen, Yeo, & Yang, 2005) has been presented a singularity-free path planning algorithm inside the reachable workspace of parallel manipulators. This algorithm includes of two parts: nominal path planning and local routing. In the nominal path planning, an optimal path is discovered connecting the beginning pose and the end pose avoiding bulk of the singularity points. (Gallant, Boudreau, & Gallant, 2012) Geometric method has been used to determine the dexterous workspace of two architectures of kinematically redundant planar parallel manipulators. The architectures analyzed are the n-RRRR and the n-RRPR. These architectures are described by having a revolute actuator as the kinematically redundant actuator added to the base of each kinematics chain.

2. Classification of the workspace

The following are some of the categories of workspaces depending on the behavior of the manipulator:

2.1 Reachable Position Workspace: The reachable workspace, as defined by Gupta, K. and B. Roth (1982), is the set of points that can be reached by a reference point on a manipulator with at least one orientation and does not include singular points where the manipulator loses one or more degrees of freedom Kucuk, S. and Z. Bingul (2005).

2.2 Dexterous Workspace / Full Orientation Angle Workspace: The fully dexterous

workspace or the full orientation angle workspace is defined as a space in which a point is approached in all directions. For these points, the range of approach angles is 360 degrees Kumar, A. and K. Waldron

(1981). For any point in the dexterous workspace the manipulator's end-effector can be "completely rotated about any (every) axis through that point" Vijaykumar, R., M. Tsai and K. Waldron (1985).

2.3 Orientation Angle Workspace: "The orientation angle workspace is the set of angles with which the end-effector can reach with a certain orientation for any point in the reachable position workspace" Li, R. and J. S. Dai (2009).

2.4 Partial Orientation Angle Workspace: "The partial orientation angle workspace is defined as a space in which a point can be approached by a range of angles that is less than 360 degrees" Li, R. and J. S. Dai (2009).

2.5 Workspace Index: Workspace Index (WSI) quantifies the points in the workspace which can be achieved by the manipulator without exceeding any physical limitations. In the discrete form the WSI is given as (Puglisi et al., 2012).

3. Theoretical Model

As earlier stated, the purpose of this work is to develop an algorithm that will enable direct and continuous estimation of a robot arm joint angle in real time using data fuse from accelerometers and inertial measurement units. The work further entails obtaining of rotational matrix of data for measuring joint parameters. The joint parameters include joint angle, angular velocity, and angular acceleration. The relationship between the various joint parameters is important in the development of the matrix. Angular velocity is calculated using the formula

$$\omega = \frac{\theta}{t} \quad (1)$$

Where: (ω) is the angular velocity, (θ) and (t) are angular displacement and time respectively.

Angular displacement is calculated using the formula;

$$\theta = \omega_0 t + \frac{1}{2} a t^2 \quad (2)$$

In the equation (2) above, (a) is the angular acceleration, and (ω_0) is the initial velocity. Angular acceleration can be calculated using the formula in equation (3);

$$a = \frac{d^2 \theta}{dt^2} \quad (3)$$

Also, angular torque can be calculated by using the formula in equation 4 below;

$$T = a \cdot I \quad (4)$$

In equation (4), (I) is the moment of inertia. Assuming that the arm will be moving from rest i.e. when $\omega=0$, then the angular acceleration can be calculated using the formula below

$$\theta = 0t + \frac{1}{2}at^2 \quad (5)$$

$$\theta = \frac{1}{2}at^2 \quad (6)$$

From above equation, it can be seen that angular displacement is related to angular acceleration. If the angular acceleration is measured, the angular displacement can be calculated. The angular acceleration can be measured using a combination of accelerometers and inertial measurement units consider a two joint robot arm with two degree of freedom as shown in Figure 1.

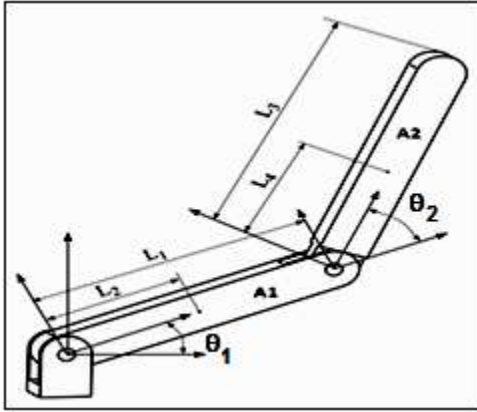

Figure 1

In the above diagram, θ_1 represents the angle arm A1 makes with the x-axis i.e. the ground, and θ_2 represents the angle arm A2, makes with arm A1. L_1 and L_4 represent different lengths. Arm A1 has a length L_1 while Arm A2 has length L_3 . Lengths L_2 and L_4 are the half-length of A_{1m} A1 and Arm A2 respectively. The arm A1 is restricted to a rotation of $\pi/2$ while Arm A2 can rotate to a maximum of π . The rotation of the arms can be modeled as shown in the Figure 2.

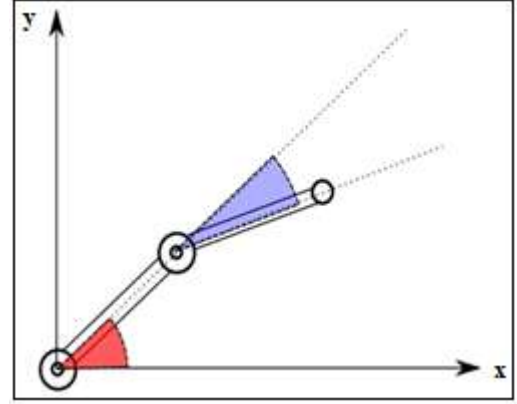

Figure 2

4.1 Derivation of Rotational Matrix of the Data.

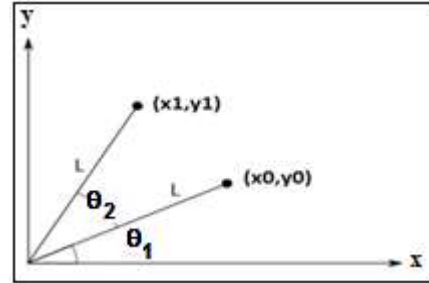

Figure 3

In Figure 3, the position of the arm shifts from point (x_0, y_0) to a new point (x_1, y_1) . The rotation is about the origin by angle θ_2 . L represents the length of the arm. Since it's a rotational motion, the length, L remains constant. Therefore;

$$x_0 = L * \cos(\theta_1) \quad (7)$$

$$y_0 = L * \sin(\theta_1) \quad (8)$$

$$\text{Where: } \cos(\theta_1) = \frac{x_0}{L}, \sin(\theta_1) = \frac{y_0}{L}$$

Also, using similar triangles theorem,

$$\cos(\theta_1 + \theta_2) = \frac{x_1}{L} \quad (9)$$

$$\sin(\theta_1 + \theta_2) = \frac{y_1}{L} \quad (10)$$

cosine $(\theta_1 + \theta_2)$ can also be expressed as

$$\cos(\theta_1 + \theta_2) = \cos(\theta_1) \cos(\theta_2) - \sin(\theta_1) \sin(\theta_2) \quad (11)$$

$$\sin(\theta_1 + \theta_2) = \sin(\theta_1) \cos(\theta_2) + \sin(\theta_2) \cos(\theta_1)$$

(12)

Combining the above equations, we have

$$\frac{y_1}{L} = \sin(\theta_1) \cos(\theta_2) + \sin(\theta_2) \cos(\theta_1) \quad (13)$$

And

$$\frac{x_1}{L} = \cos(\theta_1) \cos(\theta_2) - \sin(\theta_1) \sin(\theta_2) \quad (14)$$

Simplifying,

$$X_1 = x_0 \cdot \cos(\theta_2) - y_0 \cdot \sin(\theta_2) \quad (15)$$

$$Y_1 = x_0 \cdot \sin(\theta_2) + y_0 \cdot \cos(\theta_2) \quad (16)$$

Therefore, rotating the arm length by θ_2 degrees will result into the following rotational matrix.

$$\begin{bmatrix} x_1 \\ y_1 \end{bmatrix} = \begin{bmatrix} \cos(\theta_2) & -\sin(\theta_2) \\ \sin(\theta_2) & \cos(\theta_2) \end{bmatrix} \begin{bmatrix} x_0 \\ y_0 \end{bmatrix} \quad (17)$$

Since there is a need to move the x and y coordinates by a and b respectively, then the following results are gotten.

$$= \begin{bmatrix} x_0 \\ y_0 \\ 1 \end{bmatrix} \begin{bmatrix} \cos(\theta_2) & -\sin(\theta_2) & a \\ \sin(\theta_2) & \cos(\theta_2) & b \\ 0 & 0 & 1 \end{bmatrix} \quad (18)$$

In the above example, the rotation is about the x-y plane.

4. Discussion and Results

In this work a mathematical model developed, Matlab software was applied for finding the Workspace of four robot arms manipulator with different DOF.

The motion of end effector in cartesian space for two link planar robot manipulator has been found in this analysis without considering gravitational force and joint torque where the joint angle ' θ_1 ' of link 1 is change from 0 to $\pi/2$ and joint angle ' θ_2 ' of link 2 is change from 0 to π with respect to time.

The model is applied on the scorbot ER 4U robot as shown in the Figure 4 and the result of the model shown in the Figure 5 workspace model.



Figure 4 Scorbot Er 4u

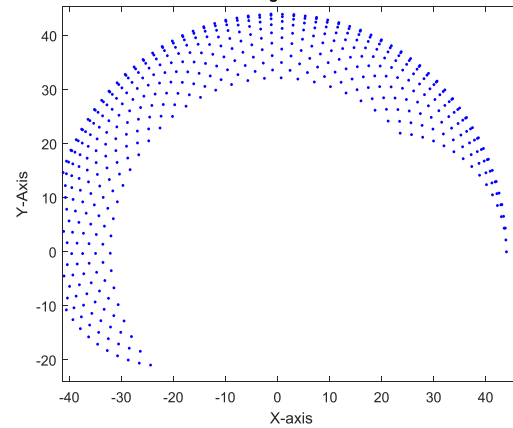

Figure 5 coordinates x-y During Rotation of Arm A1 and A2

It is also applied on the robot manipulated shown in the Figure 6 and the result of the model shown in the Figure 7.



Figure 6 Two Link Robotic Manipulator

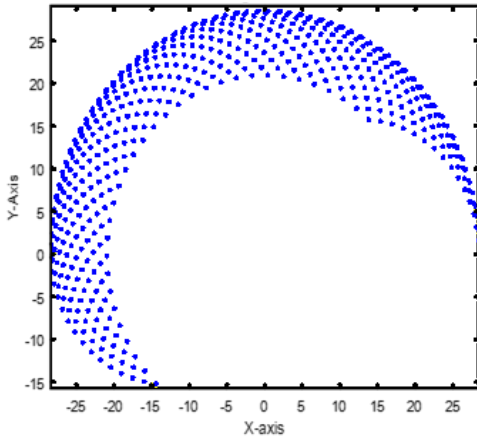

Figure 7 Coordinates x-y During Rotation of Arm A1 and A2

The model was applied on the Robot manipulator design for PhD. project by researchers Dler S. Hasan et al. (2017) the robot and the output of the model shown in the figures 8 and 9 respectively.

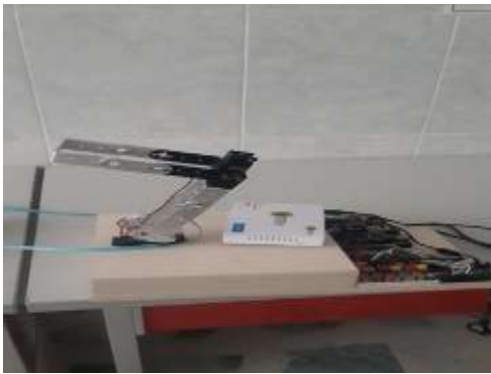

Figure 8 Robot Designed By Reserchers Dler S. et al

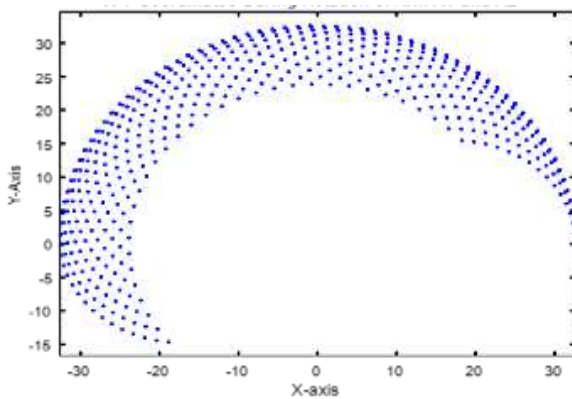

Figure 9 Coordinates x-y during Rotation of Arm A1 and A2

At last the model was applied on the robot shown in

Figure 10 and the result is shown in the Figure 11.



Figure 10 Two Link Robotic Manipulator

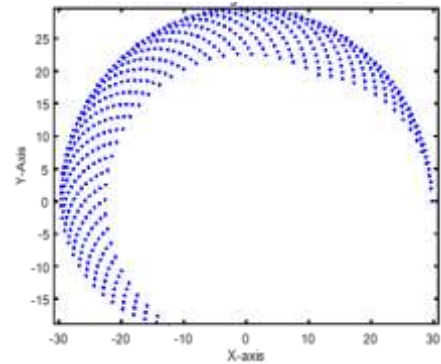

Figure 11 Coordinates x-y During Rotation of Arm A1 and A2

There is a very good similarity found of our work with the ScorbotEr 4u Robot workspace. Since the other robots have no source to compare with.

5. Conclusion

The workspace plays an important role in the decision making of designing a robotic manipulator for a specific application. In this paper a mathematical model was presented to compute a work space position in 2-D based computer simulation was proposed based on the model using Matlab software and applied four different manipulators for finding the Workspace Volume. The results are graphically presented. This method is efficient and has reasonable results since it uses the random angles in the joint angle range. This method is simple and easy to interpret.

Nomenclature

ω : Angular velocity (rad/s)

θ : Angular displacement (rad)

t : Is the time (s)

T: Angular Torque (kg rad/m²s²)

I: Moment Of Inertia(kg/m²)

a: Angular acceleration (rad/s²)

θ_1 : represents the angle arm A1 that makes with the x-axis(degree)

θ_2 : represents the angle arm A2 makes with the x-axis(degree)

L1: Length of Arm A1 (cm)

L3: Length of Arm A1(cm)

L2:Half-length of Arm A1(cm)

L4: Half-length of Arm A2 (cm)

References

- [1] Bi, Z. and S. Lang (2009). "Joint workspace of parallel kinematic machines." *Robotics and Computer-Integrated Manufacturing* 25(1): 57-63.
- [2] Chaudhury, A. N. (2017). "Kinematic Design and Optimal Synthesis of Parallel Manipulators Using Monte Carlo Method."
- [3] Ricard, R. m. and C. m. M. Gosselin (1998). "On the determination of the workspace of complex planar robotic manipulators." *Journal of Mechanical Design* 120(2): 269-278.
- [4] Goyal, K. and D. Sethi (2010). "An analytical method to find workspace of a robotic manipulator." *Journal of mechanical engineering* 41(1): 25-30.
- [5] Cao, Y., S. Qi, K. Lu, Y. Zang and G. Yang (2009). An integrated method for workspace computation of robot manipulator. 2009 International Joint Conference on Computational Sciences and Optimization, IEEE.
- [6] Snyman, J., L. Du Plessis and J. Duffy (2000). "An optimization approach to the determination of the boundaries of manipulator workspaces." *Journal of Mechanical Design* 122(4): 447-456.
- [7] Ceccarelli, M. (1995). "A synthesis algorithm for three-revolute manipulators by using an algebraic formulation of workspace boundary." *Journal of mechanical design* 117(2A): 298-302.
- [8] Dash, A. K., I.-M. Chen, S. H. Yeo and G. Yang (2005). "Workspace generation and planning singularity-free path for parallel manipulators." *Mechanism and Machine Theory* 40(7): 776-805.
- [9] Gallant, A., R. Boudreau and M. Gallant (2012). "Dexterous workspace of n-PRRR planar parallel manipulators." *Journal of Mechanisms and Robotics* 4(3): 031009.
- [10]Gupta, K. and B. Roth (1982). "Design considerations for manipulator workspace." *Journal of Mechanical Design* 104(4): 704-711.
- [11]Kucuk, S. and Z. Bingul (2005). Robot workspace optimization based on a novel local and global performance indices. Proceedings of the IEEE International Symposium on Industrial Electronics, 2005. ISIE 2005. IEEE.
- [12] Kumar, A. and K. Waldron (1981). "The workspaces of a mechanical manipulator." *Journal of Mechanical Design* 103(3): 665-672.
- [13] Vijaykumar, R., M. Tsai and K. Waldron (1985). Geometric optimization of manipulator structures for working volume and dexterity. Proceedings. 1985 IEEE International Conference on Robotics and Automation, IEEE.
- [14]Bonev, I. A. and J. Ryu (2001). "A new approach to orientation workspace analysis of 6-DOF parallel manipulators." *Mechanism and machine theory* 36(1): 15-28.
- [15]Li, R. and J. S. Dai (2009). "Orientation angle workspaces of planar serial three-link manipulators." *Science in China Series E: Technological Sciences* 52(4): 975-985.
- [16]Puglisi, L. J., R. J. Saltaren, H. A. Moreno, P. F. Cárdenas, C. Garcia and R. Aracil (2012). "Dimensional synthesis of a spherical parallel manipulator based on the evaluation of global performance indexes." *Robotics and Autonomous Systems* 60(8): 1037-1045.
- [17]<https://engineerjau.wordpress.com/2013/07/07/on-the-basis-of-workspaces-of-robotic-manipulators-part-1>
- [18] Dler S. Hasan, C. Crane III and I. I. Hamarash (2017) "Using Inertia Sensors for Orientation Estimation of Robot Manipulators.