



University of Anbar

## Anbar Journal Of Engineering Science©

journal homepage: <http://www.uoanbar.edu.iq/Evaluate/>



# Transmitting and Receiving Ultrasound Wave Based on Laser Light

<sup>1</sup>Ahmed H. Mahmood, <sup>2</sup>Jassim M. Najim, <sup>3</sup>Wesam M. Jasim

<sup>1</sup> Department of Physics, College of Science, University of Anbar, Iraq.

<sup>2</sup> Department of Physics, College of Science, University of Anbar, Iraq.

<sup>3</sup> College of Computer Science and Information Technology, University of Anbar, Iraq.

### PAPER INFO

#### *Paper history:*

Received ... ..

Received in revised form ... ..

Accepted ... ..

#### *Keywords:*

Ultrasound Frequency, Light laser, Modulation, Transmitting and Receiving circuit.

### ABSTRACT

Our project was divided into two distinct sections, circuit transmitting and receiving ultrasound Wave Based on Laser Light. A Wien Bridge and a Triangle Wave Oscillators used to obtain a sine and a triangular wave, respectively. A comparator circuit which produces Pulse Width Modulation (PWM) that has the same frequency for triangle wave. The PWM was used to drive laser diode that produced laser light through by MOSFET transistor and received this light by receiving circuit which consists of a photodiode with resistor as a voltage divider, amplifier circuit to amplify the signal and filter to get any desired frequency. The main objective of this project primarily was to realize a transmission-reception system to transfer ultrasound Frequency via Laser without a guiding medium, using modulation with little quality loss.

© 2014 Published by Anbar University Press. All rights reserved.

## 1. Introduction

Laser is an electromagnetic wave with good coherence propagating in a space with characteristics different from normal light. Ultrasonic frequency is mechanical waves that are longitudinal compression waves with frequency greater than 20 kHz, and cannot move through the space vacuum without a physical medium, while the laser and other forms of electromagnetic radiation can propagate through the vacuum. Ultrasonic wave has an important characteristic property that is slow speed, about 100,000 times less than the electromagnetic wave. However, by creating an electronic circuit that modulates the laser ultrasound wave, it becomes possible to transmit and receive ultrasonic frequencies in space and for long distances Depending on the Laser energy, that can be used in various applications. Ultrasound is an imaging technique that uses ultrasound

signals as a carrier of information. It has wide applications such as seeing the body's internal organs, examining pregnant women, and discovering dangerous and difficult diseases such as cancer [1,2,3,4,5]. Since the Laser frequency, as high as  $(10^{13} - 10^{15})$ Hz, it has a very wide and great volume of information that can be transmitted [6,7].

## 2-Pulse Width Modulation (PWM)

Pulse Width Modulation (PWM) is the foundation of control in electronic power. The PWM is used for a wide variety show of control applications and the main use is the DC motors controlling, but it can also be used to control valves, hydraulics, and other mechanical parts. It is necessary to use the pulse width modulation to control devices because PWM is an effective current control technique that enables the control of motors speed, much more in an energy

\* Corresponding author. : Ahmed H. Mahmood ; : [ahmed.mahmood@uoanbar.u.iq](mailto:ahmed.mahmood@uoanbar.u.iq) ; +9647823658712

efficiency and usually quieter. The main advantage of PWM is the output efficiency stays high as long as the signal command is greater than the carrier signal and, is a way of delivering energy through a sequence of pulses rather than a continuously changing (analog) signal. It's very easy to generate a PWM waveform. Firstly, we generate a triangle waveform and compare this with a D.C voltage, which we adjust to control the ratio from on to off the time that you require, how fast it switches between high (on) and low(off) states. By cycling a digital signal on and off at a fast-enough rate, the output will be a constant voltage analog signal when providing power to devices. In Our project, PWM requires two signals which are a high frequency triangular carrier waveform and the desired ultrasound "sinusoidal signal" as shown in figure.1.

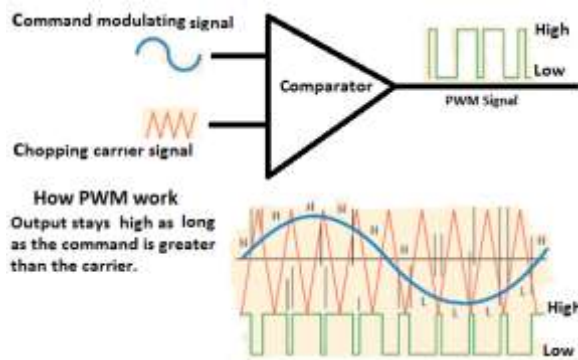

Figure1. The working of PWM.

The carrier frequency must be a stable triangular waveform in order to accurately rebuild the ultrasound waveform after rectifying the PWM signal. The comparator is used to compare the magnitudes of the carrier and the ultrasound waveform. When the magnitude of the sinusoidal ultrasound waveform is less than the magnitude of the triangular carrier waveform, the output Pulse Width Modulation "PWM" is "low", and if the magnitude of the sinusoidal ultrasound waveform is greater than the magnitude of the triangular carrier waveform, then the Pulse Width Modulation "PWM" output is "high". This analog signal can be transmitted with low and high voltages with any digital transmission process. The original ultrasound signal in a digital form may be transmitted with a laser. This process requires a fast-switching MOSFET driver that is able to switching at the frequency of the carrier signal. The laser driver and laser beam pulse for different lengths of time. The following step consists of the acknowledgement of the signal by a photodiode receiver, which must also be able to emanate a voltage proportional to that of the laser's beam as quickly as the carrier frequency is switching. The design will be

discussed in the following section, Circuit Design [8,9,10].

### 3- Circuits Designing

Two distinct sections were used Transmitter and receiver circuits. Transmitter circuit used to generate ultrasound wave and convert it to PWM then send it as a laser light, while the receiver circuit used to receive laser light and re-convert it to ultrasound wave.

**3-1 Transmitter Circuit:** It consists of four stages as follows

**3-1-1. Wien Bridge Oscillator:** It's a basic standard circuit used to generate sine waves from 1Hz to 1MHz, its built of a group of a series capacitor – resistor and a parallel capacitor – resistor connections with operational amplifier, this group is controlled on frequency range. The output frequency depends on the time of charging and discharging of the capacitor. It has low distortion, high quality of resonant frequency, and also in the tuning. The two resistors ( $R_1, R_2$ ) are used to control amplifying input signal, the output is fed to non-inverting input by (RC) parallel and (RC) series combination. as shown in Figure 2, [1,11,12].

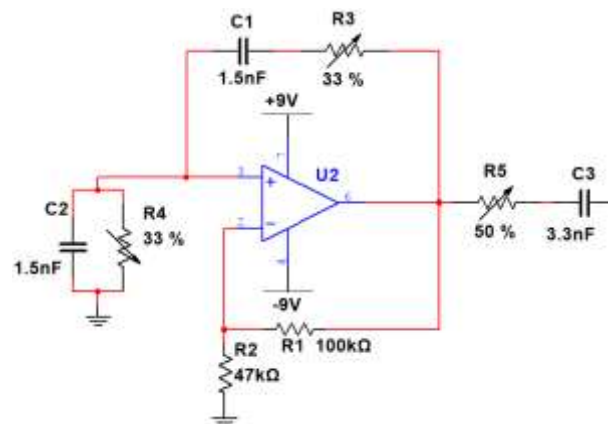

Figure 2. Wien Bridge Oscillator

Two conditions must be found for true operation of Wien Bridge Oscillator [10].

1. The phase shift must be  $0^\circ$  of the positive feedback loops.
2. By using resistors network, the amplifier gain should be one.

To simply use of Wien Bridge Oscillator put ( $C_1 = C_2, R_3 = R_4$ ).

So

$$f = \frac{1}{2\pi RC} \quad (1)$$

Where  $f$  = frequency,  $R$  = resistor,  $C$  = capacitor.

The amplifier gain can be calculated by

$$A_v = 1 + \frac{R_1}{R_2} \quad (2)$$

Where  $A_v$  = voltage gain.

**3-1-2. Triangular Wave Oscillator:** It's a basic standard circuit used to generate a square and triangle wave, it's built of a comparator circuit with integrator circuit connections together, the output of comparator circuit is fed to integrator circuit as shown in Figure 3.

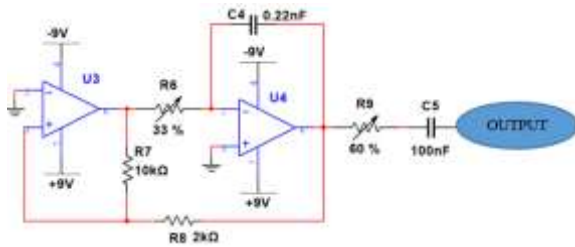

Figure 3. Triangular Wave Oscillator

In the above circuit, the output amplitude can be adjusted by using the two resistors ( $R_7, R_8$ ) getting the lower trigger point (LTP) and the upper trigger point (UTP) as in the equations below.

$$V_{UTP} = +V_{max} \left( \frac{R_8}{R_7} \right) \quad (3)$$

$$V_{LTP} = -V_{max} \left( \frac{R_8}{R_7} \right) \quad (4)$$

Where  $+V_{max}$  and  $-V_{max}$  are positive and negative saturated amplifier voltage respectively.

The frequency and time constant of triangle wave can be found by the value of capacitor and resistor ( $C_4, R_6$ ), the frequency can be adjusted by resistor ( $R_6$ ) without changing in output amplitude. To calculate the frequency use equation (5) [11,12,13].

$$f = \frac{1}{4R_6C_4} \left( \frac{R_7}{R_8} \right) \quad (5)$$

The form output square and triangular waves are shown in Figure 4 [11].

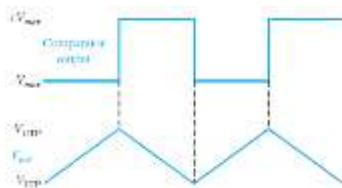
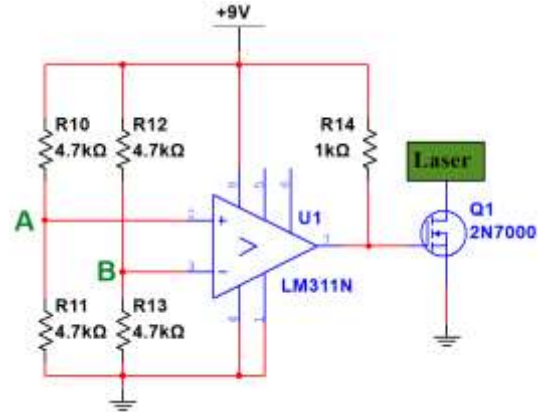

Figure 4. Output oscillator Waveforms.

**3-1-3 comparator circuit:** as shown in Figure 5, circuit is used to compare two input signals coming from Wien Bridge and Triangular waves to pro-

duce Pulse Width Modulation (PWM) which is used to drive MOSFET (work as a switch), the MOSFET drives the laser diode to get laser Light. The sine wave (30KHz) is fed to the non-inverting input (A) and the triangular wave (250KHz) is fed to inverting input (B), the output frequency has the same value



of triangular wave [14,15].

Figure 5. Comparator circuit

The laser diode used in this work is Laser Dot Modul with 650nm and 5mW. The general figure of transmitter circuit is shown in Figure 6.

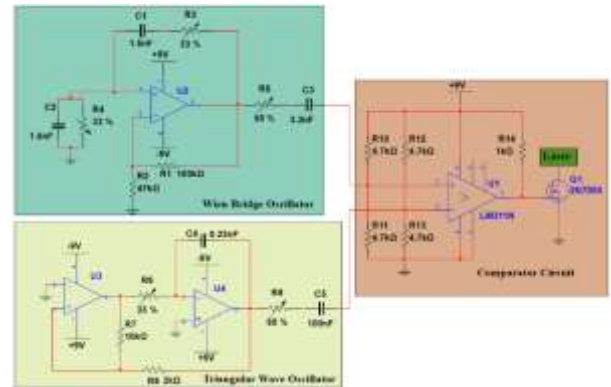

Figure 6. Transmitter circuit

**4- Receiver Circuit:** It consists of detector circuit as a voltage divider, two filters and amplifier part. The photodiode used in this work is SFH 229. The received circuit is shown in Figure 7.

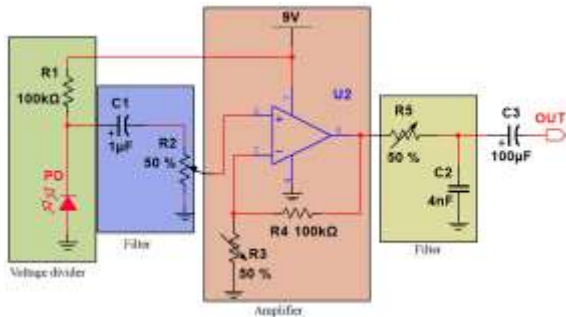

Figure 7. Receiver circuit

## 5- Experimental and Simulation Test:

We made comparison between the test circuits using simulation Multisim 14.1 program from National Instruments Company and test circuits using experimental work.

**5.a.1- Transmitting Simulation Test:** By using Multisim 14.1 program, we get for Wien bridge the output signals with amplitude about ( $V_{pp} = 5.6V$ ) and frequency equal 31.6KHz, for Triangular wave the output signals with amplitude about ( $V_{pp} = 6V$ ) and frequency equal 350KHz. The output wave is shown in figure (8) and figure (9) below.

**5.a.2- Transmitting Experimental result:** By using experimental work, we get for Wien Bridge the output signals with amplitude about ( $V_{pp} = 5.68V$ ) and frequency equal 30.6KHz, for Triangular wave the output signals with amplitude about ( $V_{pp} = 6V$ ) and frequency equal 251KHz. the output wave is shown in figure (7) and figure (8) below.

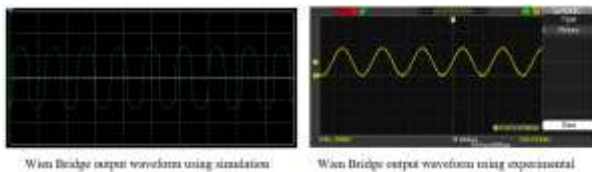

Figure (8). output waveform of simulation and experimental test for Wien Bridge Oscillator.

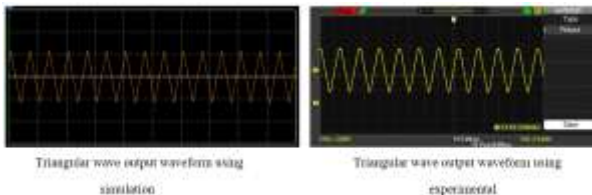

Figure (9). output waveform of simulation and experimental test for Triangular Wave Oscillator

For transmitting circuit after doing the simulation and experimental Work, using oscilloscope, we get Pulse Width Modulation (PWM) which is used to drive the MOSFET to regulate the Laser diode emission as shown in Figure 10.

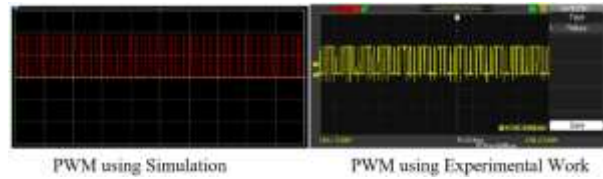

Figure 10. Pulse Width Modulation (PWM)

## 5.b-Receiving Circuit Experimental Test:

After the laser light falls on the receiving circuit detector, the incoming laser signal is processed by the receiving circuit through the voltage divider (the photodiode and resistor diode), amplified using the amplifier circuit and filtered by ( $R_5, C_2$ ), we can obtain the final output signal which is the same as the above ultrasound wave frequency with 30 kHz as shown in Figure 11.



Figure 11. Output signal after receiving circuit

## Conclusions

There was a coincidence between the theoretical simulations, and the practical results in the transmission and receiving circuits. The experimental results of PWM indicated that it is not expensive, the cost is low to make local area network (LAN) application, including outlook more highly interactive offices, hospitals, and automated operation factory. The PWM technique has been revisited and analyzed to estimate its advantage, for application to analog signal transmission in fiber-optic links. Future Fourier analysis of the PWM signal reveals that it can be used as a vehicle to launch an analog signal onto optical fiber when a symmetrical natural sampling process is used. Due to the various applications of the ultrasound and the laser, this electronic circuit was designed to allow the ultrasonic waves transfer to long distances based on the laser energy used and which can be developed to be used for a wide range of ultrasonic frequencies. PWM generation was used to drive the laser through the MOSFET, for any distance then it is received using the receiving circuit, and to get the origin ultrasonic wave (30KHz) through detector, amplifier, and low pass filter circuits, and it can be used in any application for ultrasonic wave.

## References

- [1] Jassim M. Najim, Wesam Jassim, and Ahmed H. Mahmood. Pulse Width Modulation Generation Based on Laser Using Ultrasonic Frequency. Journal of Physics: Conf. Series 1178 (2019) 012028, IOP Publishing.
- [2] J. David N. Cheeke. Fundamentals and Applications of Ultrasonic Waves. CRC press , 2002,USA.
- [3] Hugh D. Young, Roger A. Freedman, Boston and sons wesly. University Physics with Modern Physics, 2012, 13<sup>th</sup>ed, USA.
- [4] Brian M. Lempriere, Ultrasound and Elastic Waves. 2002,1st Edition.
- [5] Dong Chen, Sanjay K. Sharma, Ackmez Mudhoo, Handbook on Applications of Ultrasound, 2012, P (41-42).
- [6] Lan Xinju et al, Laser Technology, 2010, 2<sup>th</sup>ed, P (1).
- [7] Koichi Shimoda, Introduction to Laser Physics. 1986, 2<sup>th</sup>ed, P (1).
- [8] Thomas L. Floyd, David M. Buchla, Analog Fundamentals. 2013, P (290-292).
- [9] Adel S. Sedra, Kenneth C. Smith, Microelectronic Circuits.2015, 7<sup>th</sup>ed, P (967-970).
- [10] David L. Terrell, OP AMPS Design, Application, and Troubleshooting. 1996, 2<sup>th</sup>ed, P (174-175).
- [11] Smith, PR, Cowell, DMJ and S Freear, Width-modulated square-wave pulses for ultrasound applications. IEEE Transactions on Ultrasonics, Ferroelectrics, and Frequency Control. 2013, V.60 , Issue: 11 ,P(2244 - 2256).
- [12] Thomas L. Floyd, Electronic Devices, Electron Flow Version. 2012, 9<sup>th</sup>, (810-812).
- [13] Technology, B.L. Theraja, A.K. Theraja, A Text-bookof Electrical.2005, Vol. I.
- [14] Robert L. Boylestad, Louis Nashelsky, Electronic Devices and Circuit Theory. 2013,11<sup>th</sup>ed.
- [15] Pulkit Swami, Pradeep Singh. Laser Light Based Voice and Data Transmission and Electric Appliance Automation, International Advanced Research Journal in Science, Engineering and Technology. April 2016, V. 3, Issue 4, P (184-189).