



University of Anbar

# Anbar Journal of Engineering Science

journal homepage: <https://ajes.uoanbar.edu.iq/>



## Miniaturized Multiband Reconfigurable Antenna at Sub-6 and mm-Wave Band Based on Fractal Geometry

Shimaa Sh. Wole<sup>a</sup>, Mohammed K. S. Al-Mashhadani<sup>b</sup>

<sup>a</sup> Department of the Electrical Engineering, College of Engineering, University of Tikrit, Iraq  
Email: [shimaa.sh.wole@st.tu.edu.iq](mailto:shimaa.sh.wole@st.tu.edu.iq); ORCID: <https://orcid.org/0009-0006-1753-8511>

<sup>b</sup> Department of the Electrical Engineering, College of Engineering, University of Tikrit, Iraq  
Email: [mohamedkamil@tu.edu.iq](mailto:mohamedkamil@tu.edu.iq); ORCID: <https://orcid.org/0000-0002-7022-8196>

### PAPER INFO

#### Paper History

Received: 10/07/2024

Revised: 15/11/2024

Accepted: 08/12/2024

#### Keywords:

Reconfigurable antenna

5G system

Sub-6 GHz band

mm-wave band



Copyright: ©2023 by the authors. Submitted for possible open access publication under the terms and conditions of the Creative Commons Attribution (CC BY-4.0) license.

<https://creativecommons.org/licenses/by/4.0/>

### ABSTRACT

This work presents a compact reconfigurable antenna based on fractal geometry. The investigation discusses the challenges of lower antenna gain and bandwidth, critical for efficient data propagation in 5G systems, particularly for low-profile devices. Its goal is to develop a small, multiband antenna capable of operating in all current and future 5G bands and improve bandwidth and gain for mm-wave and sub-6 GHz applications. The proposed design covers the sub-6 band (2.8, 3.9, 4, 6.2) GHz and the mm-wave band (24.4, 27.1, 28.5, 29.3, 30.6, 33.9, 34.6, 35.2, 38.8, 44.4, 45.1, 59.7, 61.5, 62.3, 65.2, 67.4 and 69.5) GHz with S11 less than -10 dB. A maximum gain of 12.8 dB and a radiation efficiency of 94% are achieved. A partial ground plane with a 50 Ω feed line is used in this design. The antenna is printed on a Roger RT 5880 substrate with a relative dielectric constant 2.2 with a total dimension of 35×32.5×0.8 mm<sup>3</sup>. The proposed design is simulated using CST software, ensuring accurate calculations and performance evaluation.

## 1. Introduction

5G devices running in the Sub-6 GHz band can provide enough coverage for suburban and rural areas. Therefore, there is a trade-off between the considerably faster millimeter wave speeds in limited regions and the more extensive coverage at slower speeds of Sub-6 GHz. However, in specific scenarios (such as densely populated cities), it is more advantageous to employ both the millimeter wave and Sub-6 GHz bands to reap the benefits of 5G fully [1]. Reconfigurable antenna (RA) technologies are gaining traction as workable.

solutions because of their ability to adjust to ever-changing wireless operating conditions and system needs [2]. Through structural adjustments, the RAs may adjust the antenna's current distribution and performance factors, including resonance frequency. [3], polarization [4], and radiation pattern [5], to meet unique needs [6], [7]. Generally speaking, several methods can be employed to achieve this reconfiguration functionality, including the use.

of varactor diodes [8], FET [9], PIN diodes [6], and RF-MEMS (Micro-Electro-Mechanical Systems) [10], which are devices that, by acting as switches and permitting modifications to their properties, can alter the physical configuration of microwave circuits [11]. One of the initial design examples of a reconfigurable wearable antenna implemented on a fabric substrate for 5G sub-6 work on the MID band (3 – 5.5GHz) of 5G communications was reported by [12]. In another approach, [13] has presented a compacted ( $44 \times 44 \times 3.2 \text{ mm}^3$ ) frequency reconfigurable microstrip antenna that uses electrical switching with PIN diodes for the WiMAX (3500 MHz- 3910 MHz) and high-frequency LTE (3500 MHz and 2600 MHz) bands. Extending this objective, [14] presented a procedure to model a PIN diode RF switch using a full-wave EM solver, HFSS. The antenna demonstrates a -10 dB impedance bandwidth from 500 MHz to 6 GHz in the ultra-wideband mode and 1.125 GHz to 2 GHz in the narrowband mode. Next, in [15], a substrate layer of FR-4-based low-profile material with a total dimension of  $80.3 \times 80.3 \text{ mm}^2$  has multiband frequency tunability with a maximum frequency tunability of 100 MHz. In a recent development [16] a reconfigurable antenna design was designed for 5G applications using CST Microwave studio; the antenna is printed on ( $25 \times 29 \times 1.6 \text{ mm}^3$ ) FR-4 substrate ( $\epsilon_r=4.3$ ) operates in (3.8-5.1) and (5.9-7.76) GHz. However, the selected band suffered from limited propagation, small gains of 1.2 dBi, and a single linear. In [17] the configuration of a micro-strip monopole patch antenna (printed antenna) (size of antenna  $60 \times 45 \times 1.6 / \text{FR-4}$  substrate) was proposed and assigned Lumped RLC boundary as a diode in the antenna to make it reconfigurable antenna. However, the antenna uses the co-axial probe to feed design for feeding purposes. A low-cost and immediately deployable 5G system for 60 GHz central frequency is presented in [18]. 5G applications primarily inspired the creation of these millimeter-wave band patch antennas. For example, the Rogers RT/Duroid5880 antenna, which measures  $18 \times 11.25 \times 0.787 \text{ mm}^3$ , can switch frequencies between 28 GHz and 38 GHz or both bands; regarding the work documented in [19]. However, the proposed antenna requires more active elements and 14 RF PIN diodes for reconfigurability. According to [20], a low-profile printed antenna measuring  $31 \times 27 \times 1.6 \text{ mm}^3$  that can be adjusted for frequency and pattern was created in three different ways. Handheld 5G devices can use the proposed antenna for sub-6 GHz 5G bands 2.6, 3.5, 4.2, 4.5, and 5 GHz. However, the complex design only covered sub-6

GHz, relying on eight PIN diodes for reconfigurability. A frequency reconfigurable antenna suitable for millimeter wave applications, four frequencies are produced in [21] using the proposed antenna, which is 49.84GHz, 31.65GHz, 31.4GHz and 45.45GHz. However, it includes a narrow bandwidth. Reported in [22] a reconfigurable antenna that operates in dual band 2.4 and 28 GHz frequency band for 5G Applications. The total size of the antenna was  $30 \times 26.5 \times 1.6 \text{ mm}^3$  and was printed on a FR-4 substrate. However, this research compares the bandwidth obtained from its different states, which range from 32.5 MHz to 2.57 GHz. In this study, a fractal frequency reconfigurable antenna with an overall size of  $35 \times 32.5 \times 0.8 \text{ mm}^3$  using a PIN diode acts as the switch between the two patch elements to enable different configurations. The main advantage of the proposed reconfigurable antenna is that it can resonate in two bands (mm-wave and sub-6 band). The proposed reconfigurable antenna uses a single antenna that radiates at multiple different frequencies; instead of two or three, it will be under two conditions: ON and OFF for pin-diodes in the partial ground.

## 2. Design steps.

Fractal geometries possess two significant characteristics: self-similarity and space-filling. Fractal geometries, when used in antenna design, enable the antenna to operate at several frequencies and have size-reduction capabilities [23]. Utilizing fractal ideas in antenna element design offers the advantages of reduced dimensions, the ability to operate across several frequency bands, and broad bandwidth capabilities. Figure 1 illustrates each step in designing the reconfigurable antenna (a, b, and c) with total dimensions  $35 \times 32.5 \times 0.8 \text{ mm}^3$ . The antenna is created using Rogers RT/5880 material, which has a relative permittivity ( $\epsilon_r$ ) 2.2 and a thickness (h) of 0.8 mm. Step (a) necessitated the utilization of a rectangular patch antenna, as depicted in Figure 1(a). The sub-6 band is not covered, and the antenna works only in the mm-wave spectrum. Step (b) streamlined specific patch components, resulting in a frequency of 3.1 GHz within the sub-6 band, as shown in Figure 2. However, the antenna's performance in the mm-wave band was unstable.

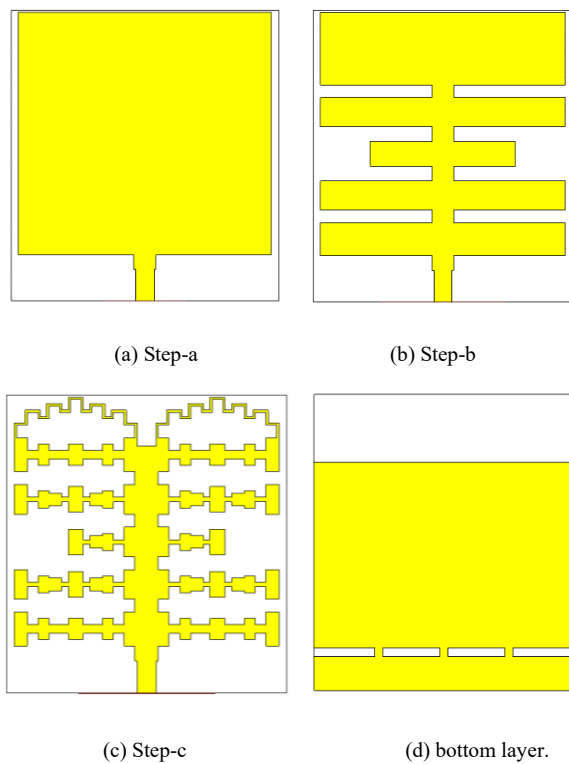


Figure 1: Proposed steps for antenna design.

Step (c) involved designing a fractional antenna capable of operating at exact frequencies for both bands as shown in Figure 2 and Figure 3. It covers the frequencies of 2.8 and 6.2 GHz within the sub-6 band and different frequencies, including 24, 27.3, 30.9, 33.9, 35.2, 44.3, 61.2, and 67.2 GHz. A microstrip line with a width of 2.2 mm and an impedance of  $50 \Omega$  is used for feeding. The reconfigurable antenna achieved significant enhancements with the addition of a ground slit, enabling it to operate in two unique modes: partial and full ground mode. Switches can be used to control the ON and OFF states [24].

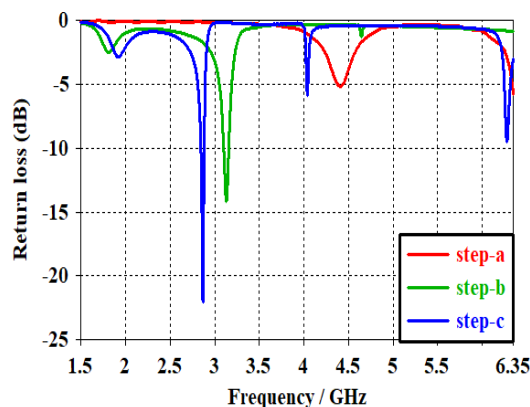


Figure 2: Return loss performances for sub-6 band.

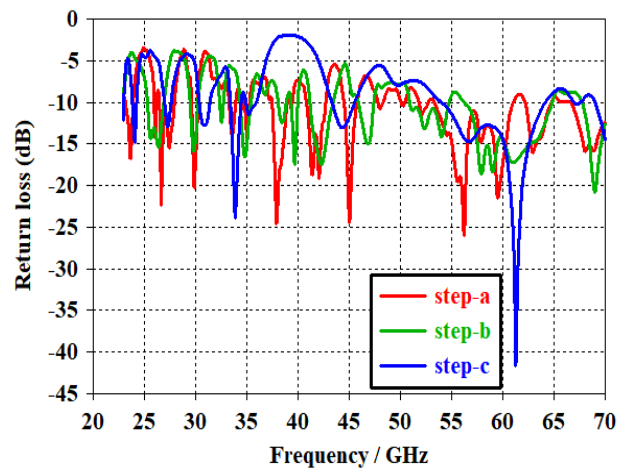


Figure 3: Return loss performances for mm-wave band.

### 3. Proposed setup.

Figure 4 shows the suggested antennas for the combined band operations of future 5G application. A reconfigurable antenna is designed based on fractal geometry. with an overall dimension of  $(35 \times 32.5 \text{ mm}^2)$ , five switches are added to the patch, and three to the ground to generate multi-band operation.

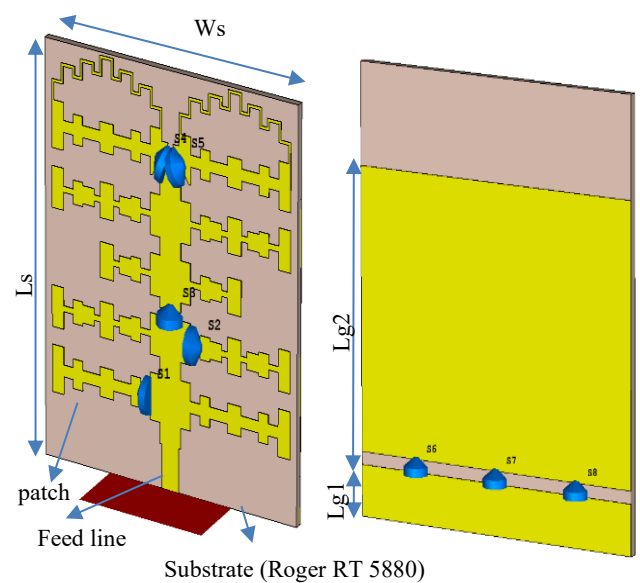


Figure 4: Proposed reconfigurable antenna.

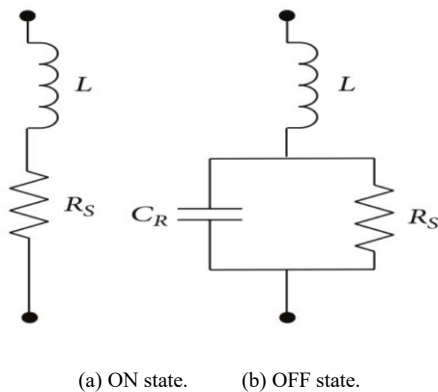
Table 1 provides an overview of the suggested design components of the reconfigurable antenna. Figure 5 illustrates the operation of the pin diode switch mode

It forms an RL series circuit with an inductor (L) and a low-value resistor (RL) when activated.

Deactivating the switch simulates an RLC circuit using a parallel combination of an inductor (L), a high-value resistor (Rh), and a capacitor (C). For this study, we utilize the Skyworks SMP1345-079LF pin diodes, which have  $RL = 1.5\Omega$ ,  $L = 0.7nH$ , and  $C = 0.15pF$  as specified in the datasheet [25].

**Table 1:** The set-up antenna dimensions.

Parameter	Symbol	Value (mm)
Width of substrate	Ws	32.5
Length of substrate	Ls	35
Highest of substrate	Hs	0.8
Width of ground	Wg	32.5
Length of ground	Lg1	4
Length of ground	Lg2	27
Highest of ground	Hs	0.035
Length of feed	Lf	3.75
Width of feed	Wf	2.2



**Figure 5:** PIN-diode equivalent circuit.

The antenna is designed with two configurations, partial and full ground plane, as shown in Tables 2 and 3. The partial ground is created when S6, S7, and S8 are OFF, while it is full ground when the switches are ON. Four states are selected for each configuration depending on the switches (S) case. State-1, in which only S1 is ON, in state-2, only S2 is ON, while S5 and S6 are OFF in state-3, and state-4, all the switches are ON. In state-1, the minimum size of the suggested antenna is shown. For this reason, the antenna starting to operate at a high frequency of 28.5, 34.6, and 65.1 GHz. For state-2, the proposed

antenna resonates at 27.1, 34.8, 45.1 and 65.6 GHz. In state 3, The antenna has a single-band characteristic; it operates at 3.9 GHz in the sub-6 band. The antenna covers the third band within the mm-wave band at 28.7, 35.2 and 65.2 GHz, respectively. On the other hand, the large size of the antenna is happened in state-4 and covers two separate bands: 2.8 and 4 GHz within sub-6 band, and 28.8, 34.6, and 65.3 GHz in mm-wave band.

**Table 2:** Simulated values of proposed antenna (config.1).

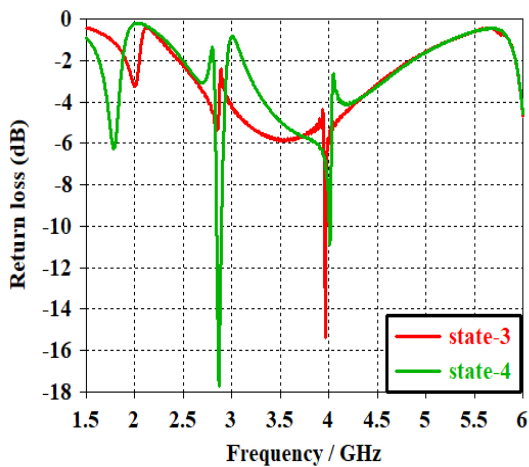
	All diodes in the ground (S6, S7, S8) OFF							
	State-1		State-2		State-3		State-4	
	ON	OFF	ON	OFF	ON	OFF	ON	OFF
S1	✓			✓	✓			✓
S2		✓	✓		✓			✓
S3		✓		✓	✓			✓
S4		✓		✓	✓			✓
S5		✓		✓		✓	✓	
S6		✓		✓		✓	✓	
Frequency (GHz)	28.5 34.6 65.1		27.1 34.8 45.1 65.6		3.9 28.7 35.2 65.2		2.8 4 28.8 34.6 65.3	
Max. Gain (dB)	6.15		6.58		11.3		11.4	

In contrast, four states in full ground case, are chosen for each configuration. In state-1, the suggested antenna operates at 34.2, 38.8, 44.4, 59.7, and 69.5 GHz frequencies, achieving a maximum gain of 12.8 dB (at 59.7 GHz). In state-2, the antenna covers the frequency bands of 29.3, 34.1, 44.4, and 62.3 GHz. For state-3, the antenna covers 24.4, 27.2, 30.6, 33.9, 35.6, 44.3, 61.5, and 67.4 GHz with a high gain of 11.2 dB. While in state-4, the same antenna covers two bands: 2.8 and 6.2 GHz for the sub-6 band and 24, 27.3, 30.9, 33.9, 35.2, 44.3, 61.2, and 67.2 GHz for the mm-wave bands.

**Table 3:** Simulated values of the proposed antenna (config.2).

	All diodes in the ground (S6, S7, S8) ON							
	State_1		State_2		State_3		State_4	
	ON	OFF	ON	OFF	ON	OFF	ON	OFF
S1	✓			✓	✓		✓	
S2		✓	✓		✓		✓	
S3		✓		✓	✓		✓	
S4		✓		✓	✓		✓	
S5		✓		✓		✓	✓	
S6		✓		✓		✓	✓	
Frequency (GHz)					24.4		2.8	
					24.4		6.2	
		34.2			27.2		24	
		38.8	29.3		30.6		27.3	
		44.4	34.1		33.9		30.9	
		59.7	44.4		35.6		33.9	
		69.5	62.3		44.3		35.2	
					61.5		44.3	
Max. Gain (dB)					67.4		61.2	
					67.2		67.2	
	12.8	10.3		11.2		11.3		

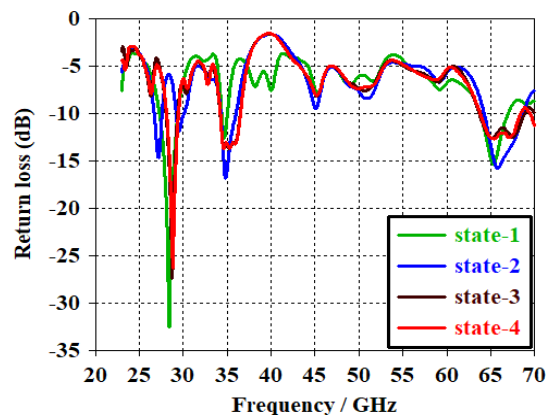
Figure 6 illustrates the simulated return loss for all states in the sub-6 bands for the proposed antenna in configuration-1 with return loss less than -17.8, -15.35, and -10.7 dB at 3.9, 2.8, and 4 GHz, respectively.



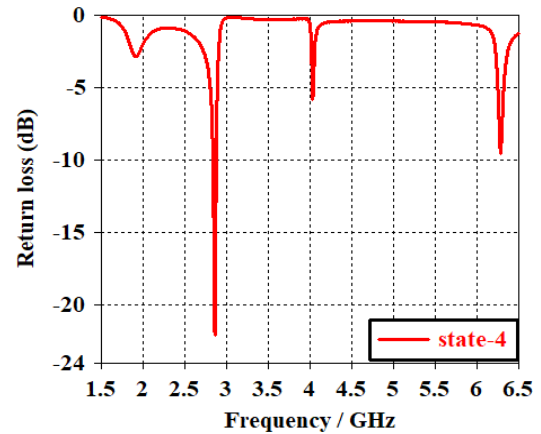
**Figure 6:** Simulated (S11) results for configuration 1 in sub-6 band.

On the other hand, Figure 7 displays the act of the S11 parameter for the millimeter-wave bands. In

state-1, the antenna operates at frequencies of 28.5, 34.6, and 65.1 GHz, with values less than -32, -12.6, and -15.3 dB, respectively. In state-2, the antenna operates at frequencies of 27.1, 34.8, 45.1, and 65.6 GHz, and it has a return loss of less than -14.6, -11.8, -16.8, and -15. dB, respectively. The highest bandwidth in this state was 4.4 GHz (at 65.6 GHz). At state-3, the proposed antenna covers 28.7, 35.2, and 65.2 GHz, with S11 parameter values of -27.3, 13.69, and -12.5 dB, respectively. with a 5.1 GHz (at 65.2 GHz) maximum bandwidth. Finally, at 28.8, 34.6, and 65.3 GHz, the return loss for the multiple band (state-4) reveals losses with respective values of -26.3, -13.6, and -12.6 dB, respectively. In this state, the highest bandwidth was 3.6 GHz (at 65.3 GHz).



**Figure 7:** Simulated (S11) results for configuration 1 in mm-Wave band.



**Figure 8:** Simulated (S11) results for configuration 2 in sub-6 band.

Figure 8 shows how the proposed antennas estimated S11 parameters work in the sub-6 band for config. 2. At 2.8, 6.2 GHz, the suggested antenna has return loss values of -22 dB. Figure 9 illustrates the act of the S11 parameter for the millimeter-wave frequency bands. Each of the four different states operates in multiple frequency ranges. The suggested antenna operated in the 24.4, 27.2, 29, 34, 30.6, 33.9, 35.6, 38, 44.3, 59.7, 61.5, and 67.4 GHz frequency bands with S11 characteristics below -12

dB and could reach -43 dB at the center frequency. The highest bandwidth in these states was 10.1GHz (at 61.2GHz).

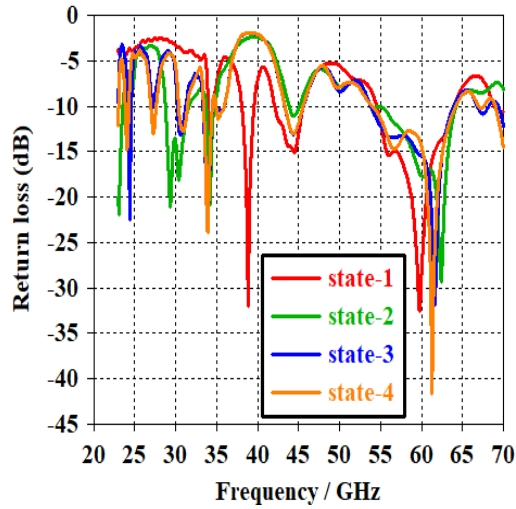
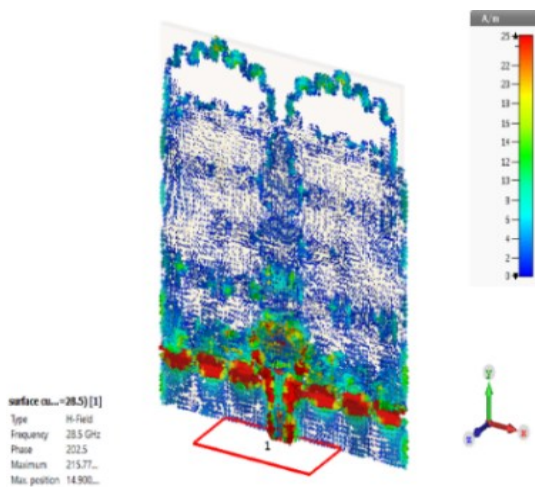
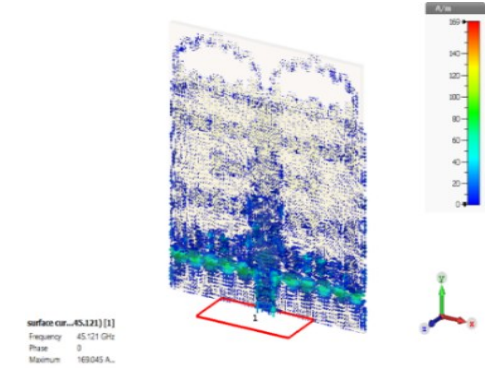


Figure 9: Simulated (S11) results for configuration 2 in mm-wave band.

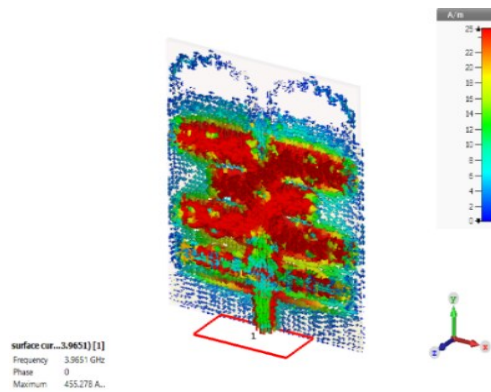
Figure 10 shows the spatial arrangement of the antenna's current distribution over multiple frequency bands. At configuration 1. The lower end of the feedline emits electromagnetic waves at 28.5, 35, 45.1, and 65 GHz because the surface has a higher electric current density. The current distribution on the surface shows a higher concentration in lower frequency compared to higher frequency bands. The antenna operates throughout a broad spectrum of frequencies, including 2.8, 3.9, 4, and 6.2 GHz. It also changes to frequencies of 30.9, 33.9, 35.6, and 38.8 GHz at configuration 2 (Figure 11), and the surface currents show a different behavior in resonant height. The surface currents illustrate that the resonant length reduces as the frequency expands, confirming the inverse relationship between frequency and resonant length.



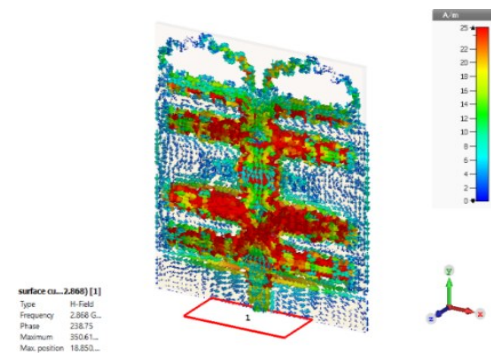
(a) State-1 at 28.5 GHz.



(b) State-2 at 45.1 GHz.

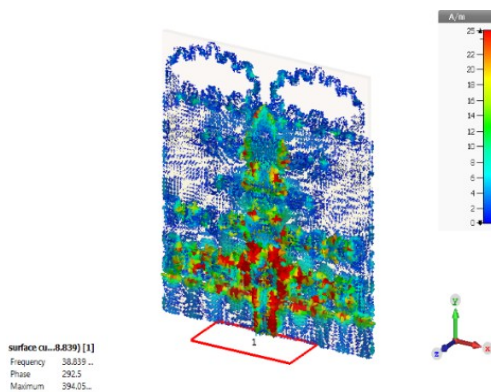


(c) State-3 at 3.9 GHz.

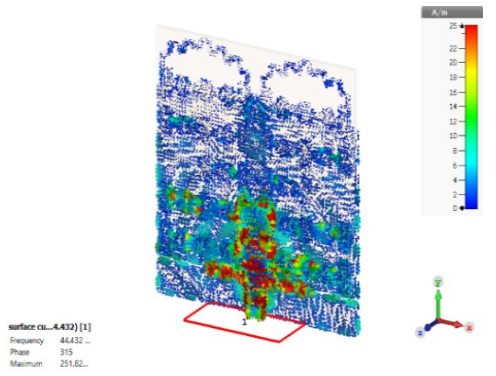


(d) State-4 at 2.8 GHz.

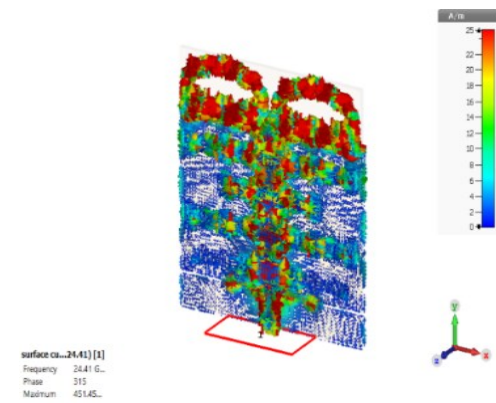
Figure 10: Antenna surface current diagrams at different states for config.1.



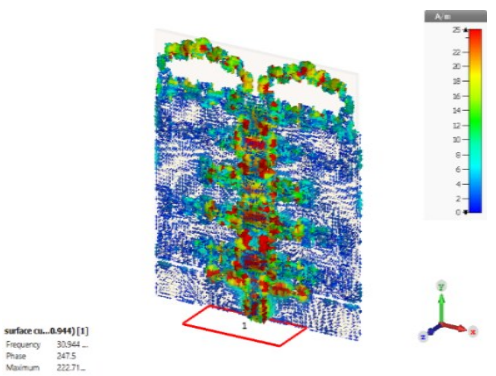
(a) State-1 at 38.8 GHz



(b) State-2 at 44.4 GHz.



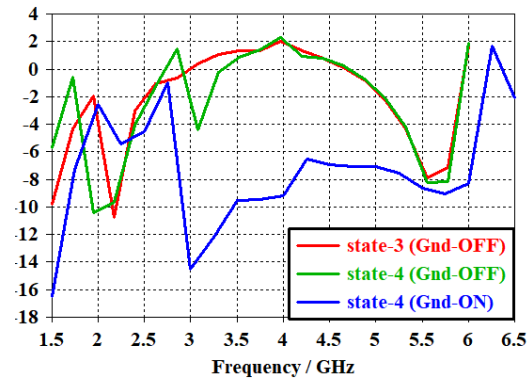
(c) State-3 at 24.4 GHz.



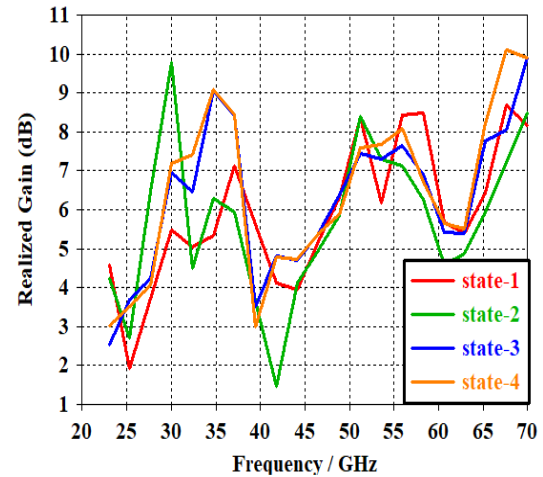
(d) State-4 at 30.9 GHz.

**Figure 11:** Antenna surface current diagrams at different states for config.2.

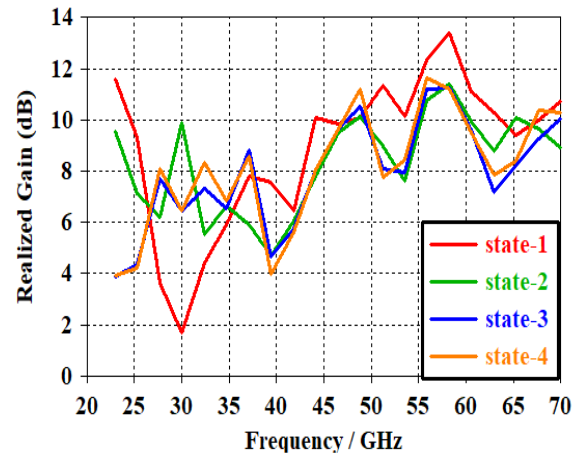
In 5G wireless systems, high gain is important because it directly reflects the power that the antenna emits through its radiation patterns [26]Figure 12 illustrates the realized gain in the sub-6 band for both configurations; the maximum simulated gain is around 3 dB for 6.2 GHz. Figure 13 and Figure 14 display the gain within the mm-wave band for config.1 and config.2, respectively. Config.2 (state-1) exhibits the maximum gain of 12.8 dB at the mm-wave band since the ground was with total dimension in it.



**Figure 12:** Gain of the suggested antenna for both configurations in the sub-6 band.

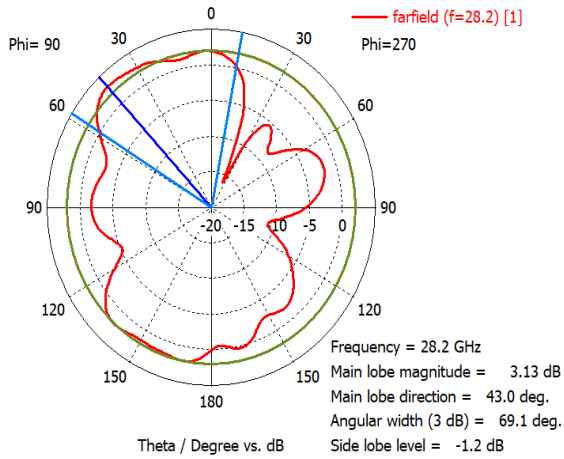


**Figure 13:** Gain of the proposed antenna for con Fig. 1 in the mm-wave band.

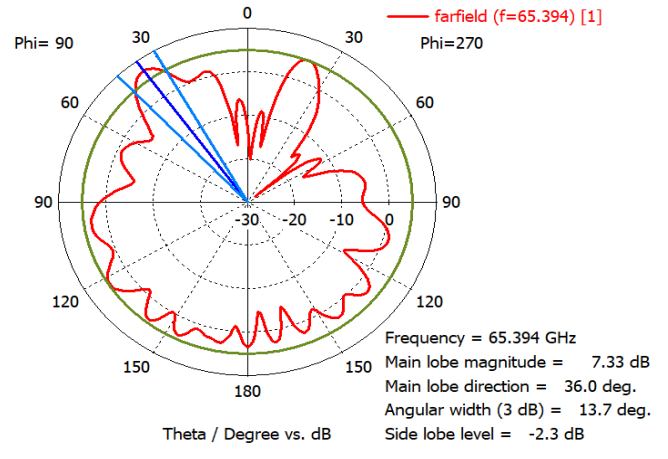


**Figure 14:** Gain of the proposed antenna for config.2 in the mm-wave band.

Figure 15 describes the radiation pattern of the proposed reconfigurable antenna in the first four states at config.1 Figure 16 shows the radiation pattern in the other four states at config.2. These patterns exhibit a directional radiation pattern that is significant for 5G applications, particularly at various frequencies.

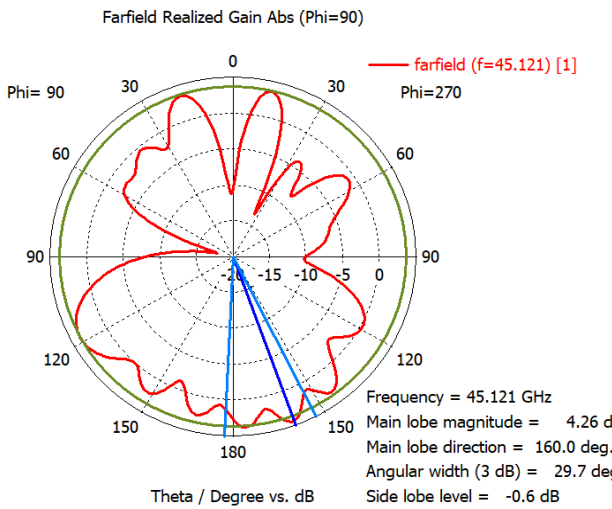


(a) State-1 at 28.5 GHz.

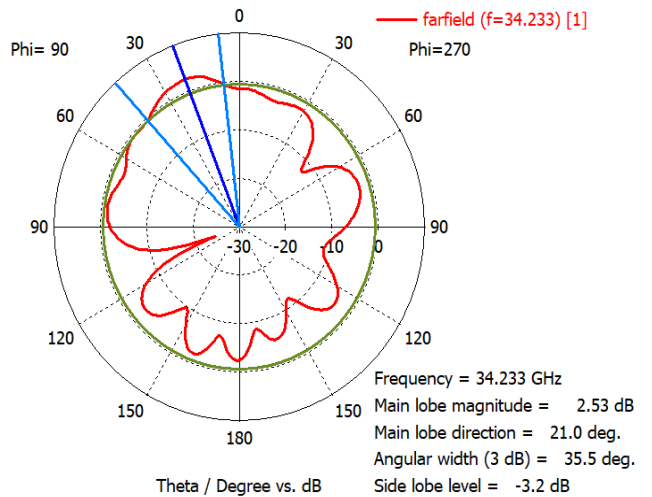


(d) State-4 at 65.5 GHz.

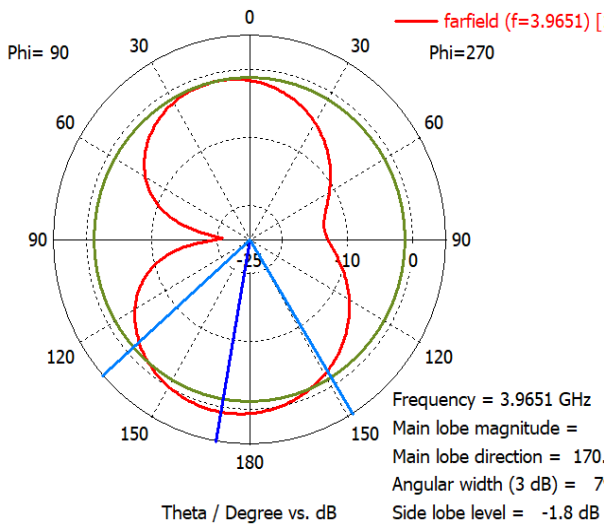
Figure 15: E-plane for some resonant frequency at config.1.



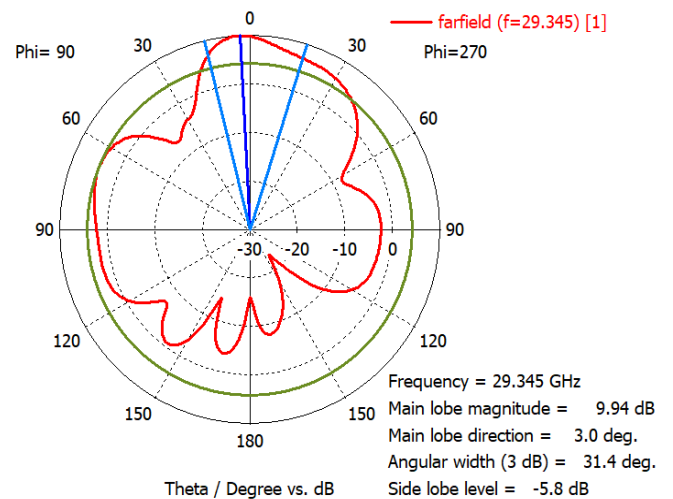
(b) State-2 at 45.1 GHz.



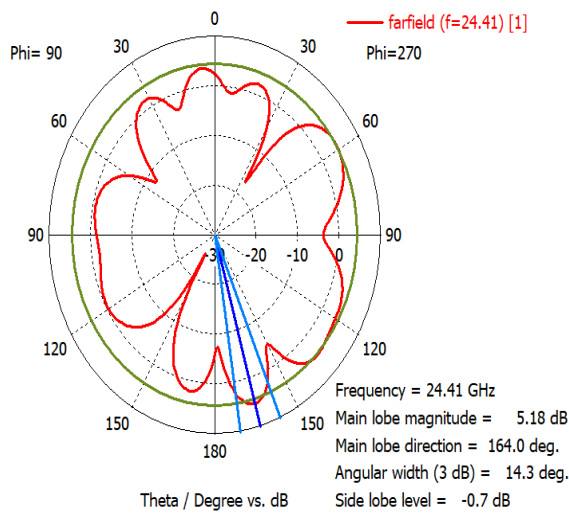
(e) State-1 at 34.2 GHz.



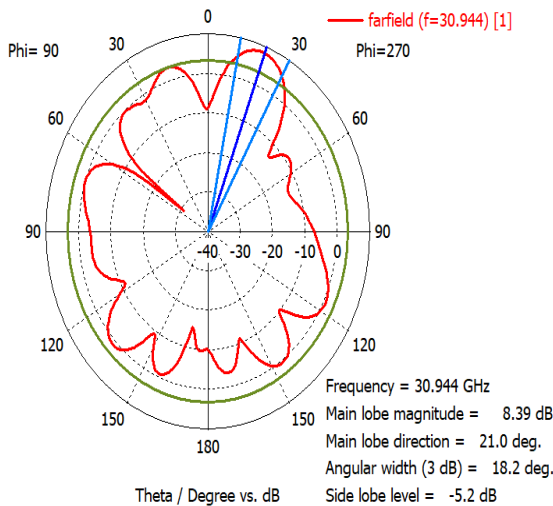
(c) State-3 at 3.9 GHz.



(f) State-2 at 29.3 GHz.



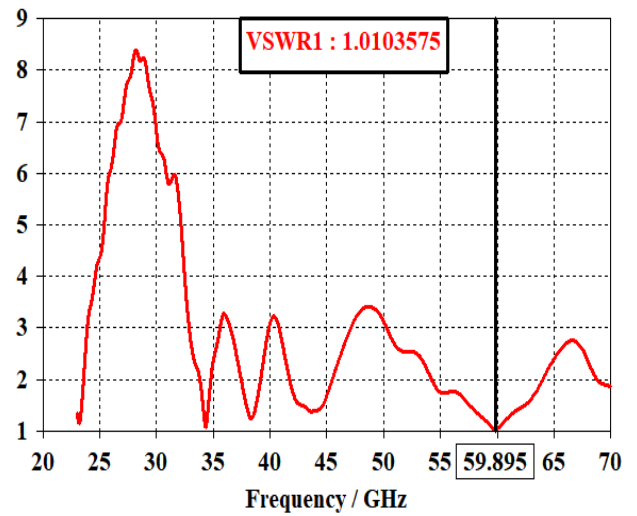
(c) State-3 at 24.4 GHz.



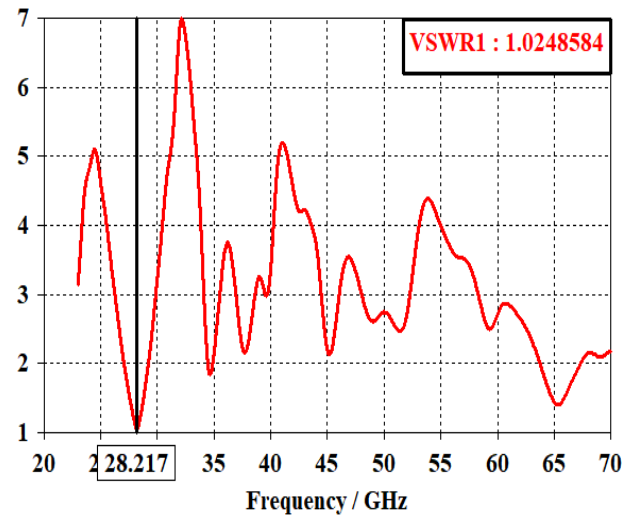
(d) State-4 at 30.9 GHz.

**Figure 16:** E-plane for some resonant frequency at config.2.

The voltage standing wave ratio (VSWR) measures the power reflected. It is considered to have a positive return-loss value since it captures a greater number of radio waves than it rejects [27]. The opposite is true, with a lower return-loss value. Figure 17 shows VSWR in state-1 (config.1) at 28.2 GHz, while Figure 18 shows VSWR in state-1 (config.2) at 59.8 GHz. This indicates satisfactory impedance matching, with a value below two considered suitable.



**Figure 17:** VSWR of proposed antenna at config.1.



**Figure 18:** VSWR of proposed antenna at config.2.

Many researchers have suggested and created antenna configurations for different frequency ranges and purposes, as seen in Table 4. The configurations include individual antennas, arrays of antennas, wideband antennas, multiband antennas, and several other antennas. In terms of size, the proposed antenna is more compact than other antennas reported in [16], [17]. The most prominent distinction, as compared to other candidate antennas, is the ability of the proposed antenna to operate in combination bands, which are more than the number of bands achieved in all reported works [19],[21], [28].

**Table 4:** Comparison of the suggested antenna with other reference antennas.

Ref	Antenna size (mm <sup>2</sup> )	Substrate ( $\epsilon_r$ )	Resonance frequency (GHz)	Frequency reconfigurable	Max gain (dBi)
[16]	25×29×1.6	FR-4 ( $\epsilon_r=4.3$ )	(3.8-5.1) and (5.9-7.76) GHz	frequency	1.2 dBi
[17]	60× 45 ×1.6	FR-4 ( $\epsilon_r=4.4$ )	1.95 to 19.33GHz	frequency	-13 dB
[19]	18×11.25 ×0.787	Rogers RT/5880 ( $\epsilon_r=2.2$ )	28 GHz and 38 GHz or both bands	tuned reconfigurable	6.72 dBi
[20]	31×27×1.6	FR-4 ( $\epsilon_r =4.3$ )	1.8, 2.1, 2.6, 3.5, 4.8, 5.0,5.6, 6.4, 6.5 GHz	frequency	190–1400 MHz
[21]	5×4×10	Rogers RO3003 (3)	49.84, 31.65, 31,4 and 45,45 GHz	Frequency	2.43
[22]	30 × 26.5 ×1.6	FR-4 ( $\epsilon_r=4.4$ )	2.4, 28	frequency	-----
[28]	100× 6 ×0.5	Roger 3003 ( $\epsilon_r =3$ )	around 27 GHz.	frequency	8
[29]	37×35×1.6	FR-4 4.3	2, 2.45, 3.1 and 3.4 GHz	frequency	Range (630 MHz-5.8GHz)
[30]	-----	RT Duroid ( $r = 2.2$ )	5.2, 5.8 GHz	Frequency and Polarization	204MHz
Our work	35 × 32.5 × 0.8	Roger 5880 RT ( $\epsilon_r=2.2$ )	2.8, 3.9, 4, 6.2 GHz in sub-6 band 24.4, 27.1, 28.5, 29.3, 30.6, 33.9, 34.6, 35.2, 38.8, 44.4, 45.1, 59.7, 61.5, 62.3, 65.2, 67.4 and 69.5 GHz in mm-wave band	frequency	12.8 dB

#### 4. Conclusion

In this manuscript, a rectangular microstrip antenna that operates at a multiband in both sub-6 and mm-wave bands is achieved together for 5G applications. The proposed antenna covers all resonant frequencies (2.8, 3.9, 4, 6.2) GHz is presented for the sub-6 band and mm-wave band at (24.4, 27.1, 28.5, 29.3, 30.6, 33.9, 34.6, 35.2, 38.8, 44.4, 45.1, 59.7, 61.5, 62.3, 65.2, 67.4 and 69.5) GHz. The antenna uses Rogers RT/Duroid5880 as a substrate with a maximum thickness of 0.8 mm. The simulation of the proposed antenna is carried out using CST. Its key characteristics are the antenna's simple shape and compact size, excellent measured performance in terms of return loss, operating bandwidth, stable high gain, and radiation efficiency. The achieved return loss, VSWR, Gain, directivity, input impedance, and radiation efficiency are -32 dB,  $1 > \text{VSWR} < 2$ , 12.8 dB, 13.7 dB, 50 $\Omega$ , and 94%, respectively.

#### Reference

- [1] M. S. S. S. Srinivas, H. Kumar, C. H. Latha, S. Suresh, B. Brahmaiah, and L. Ganesh, "Miniaturized Microstrip Patch Antennae For 5g Applications," *Journal of Engineering Sciences*, 2020. <https://doi.org/10.1109/ICECA49313.2020.9297427>
- [2] [2] S. R. Isa et al., "Reconfigurable pattern patch antenna for mid-band 5G: A review," *Comput. Mater. Contin.*, vol. 70, no. 2, pp. 2699–2725, 2022. <https://doi.org/10.32604/cmc.2022.019769>
- [3] [3] S. Ferouani and W. Moulessehouli, "Frequency Reconfigurable Pentagon Patch Antenna Using PIN Diode for Wireless Applications," vol. 2, pp. 24–28, 2021,

- <https://doi.org/10.1016/j.aeue.2020.153370>.
- [4] E. A. L. Abbas, S. Member, and N. Nguyen-trong, "Polarization-Reconfigurable Antenna Array for Millimeter-Wave 5G," *IEEE Access*, vol. 7, pp. 131214–131220, 2019, <https://doi.org/10.1109/ACCESS.2019.2939815>.
- [5] F. T. Çelik, L. Alatan, and Ö. Aydın Çivi, "A compact pattern reconfigurable antenna employing shorted quarterwave quarter-wave patch antennas," *Turkish J. Electr. Eng. Comput. Sci.*, vol. 30, no. 6, pp. 2179–2189, 2022, <https://doi.org/10.55730/1300-0632.3932>.
- [6] A. A. Palsokar and S. L. Lahudkar, "Frequency and pattern reconfigurable rectangular patch antenna using single PIN diode," *AEU - Int. J. Electron. Commun.*, vol. 125, Oct. 2020, <https://doi.org/10.1016/j.aeue.2020.153370>.
- [7] R. Shanmugam, "Design and Analysis of a Frequency Reconfigurable Penta-Band Antenna for WLAN and 5G Applications," *J. Electromagn. Eng. Sci.*, vol. 21, no. 3, pp. 228–235, Jul. 2021, <https://doi.org/10.26866/jees.2021.3.r.30>.
- [8] M. Al Ahmad, "Compact single - varactorsingle-varactor diode frequency - reconfigurable microstrip patch antenna," no. November 2020, pp. 1100–1107, 2021, <https://doi.org/10.1049/mia2.12117>.
- [9] A. Quddious, M. A. B. Abbasi, M. A. Antoniadis, P. Vryonides, V. Fusco, and S. Nikolaou, "Dynamically Reconfigurable UWB Antenna Using an FET Switch Powered by Wireless RF Harvested Energy," *IEEE Trans. Antennas Propag.*, vol. 68, no. 8, pp. 5872–5881, 2020, <https://doi.org/10.1109/TAP.2020.2988941>.
- [10] K. G. Sravani et al., "Design of reconfigurable antenna by capacitive type RF MEMS switch for 5G applications," *Microsyst. Technol.*, vol. 28, no. 3, pp. 845–853, 2022, <https://doi.org/10.1007/s00542-020-04958-8>.
- [11] A. K. Abd, J. M. Rasool, Z. S. A. S. A. Rahman, and Y. I. A. Al-Yasir, "Design and Analysis of Novel Reconfigurable Monopole Antenna Using Dip Switch and Covering 5G-Sub-6-GHz and C-Band Applications," *Electron.*, vol. 11, no. 20, Oct. 2022, <https://doi.org/10.3390/electronics11203368>.
- [12] A. Muduli, M. K. Kanneboina, and K. Vamsi, "A Reconfigurable Wearable Antenna for Mid Band 5G Applications," 2021, <https://doi.org/10.1088/1742-6596/1921/1/012051>.
- [13] K. M. Oumar and L. N. Shyan, "A compact reconfigurable slotted microstrip patch antenna using pin diode for wireless applications," in *Journal of Physics: Conference Series*, Institute of Physics Publishing, Jun. 2019. <https://doi.org/10.1088/1742-6596/1228/1/012074>.
- [14] J. Kumar, B. Basu, and F. A. Talukdar, "Modeling of a PIN diode RF switch for reconfigurable antenna application," *Sci. Iran.*, vol. 26, no. 3 D, pp. 1714–1723, 2019, <https://doi.org/10.24200/sci.2018.20110>.
- [15] S. K. Patel et al., "Multiband and Low-Proole Frequency Reconfigurable Microstrip Patch Antenna Design Using Single PIN diode for WiFi/GPS applications," 2021, <https://doi.org/10.21203/rs.3.rs-872444/v1>.
- [16] A. S. Kamel and A. S. Abdulhadi, "Reconfigurable Monopole Antenna Design Based On Fractal Structure For 5g Applications," pp. 1–10, 2021, [Online]. Available: <https://ijict.edu.iq>.
- [17] F. G. Awan, M. Latif, F. G. Awan, T. Mehmood, and M. Latif, "Reconfigurable Antenna for 4G LTE and 5G Applications," *Procedia Manufacturing*, 2022.
- [18] K. Trzebiatowski, M. Rzymowski, L. Kulas, and K. Nyka, "Simple 60 GHz Switched Beam Antenna for 5G Millimeter-Wave Applications," *IEEE Antennas Wirel. Propag. Lett.*, vol. 20, no. 1, pp. 38–42, 2021, <https://doi.org/10.1109/LAWP.2020.3038260>.
- [19] S. A. Refaat, H. A. Mohamed, A. M. Abdelhady, and A. S. S. Mohra, "A 28 / 38 GHz tuned reconfigurable antenna for 5G mobile

- communications,” *Indones. J. Electr. Eng. Comput. Sci.*, vol. 31, no. 1, pp. 248–258, Jul. 2023, <https://doi.org/10.11591/ijeecs.v31.i1.pp248-258>.
- [20] I. Ahmad et al., “Design and Experimental Analysis of Multiband Compound Reconfigurable 5G Antenna for Sub-6 GHz Wireless Applications,” *Wirel. Commun. Mob. Comput.*, vol. 2021, 2021, <https://doi.org/10.1155/2021/5588105>.
- [21] W. A. Awan, A. Zaidi, N. Hussain, S. Khalid, Halima, and A. Baghdad, “Frequency Reconfigurable patch antenna for millimeter wave applications,” *2019 2nd Int. Conf. Comput. Math. Eng. Technol. iCoMET 2019*, pp. 1–5, 2019, <https://doi.org/10.1109/ICOMET.2019.8673417>.
- [22] D. El Hadri, A. Zakriti, and A. Zugari, “Reconfigurable antenna for Wi-Fi and 5G applications,” in *Procedia Manufacturing*, Elsevier B.V., 2020, pp. 793–799. <https://doi.org/10.1016/j.promfg.2020.04.007>.
- [23] K. A. Malar and R. S. Ganesh, “Novel aperture coupled fractal antenna for Internet of wearable things (IoWT),” *Meas. Sensors*, vol. 24, no. July, p. 100533, 2022, <https://doi.org/10.1016/j.promfg.2020.04.007>.
- [24] D. N. Gençođlan, Ş. Çolak, and M. Palandöken, “Spiral-Resonator-Based Frequency Reconfigurable Antenna Design for Sub-6 GHz Applications,” *Appl. Sci.*, vol. 13, no. 15, Aug. 2023, <https://doi.org/10.3390/app13158719>.
- [25] S. Ullah et al., “A Compact Frequency and Radiation Reconfigurable Antenna for 5G and Multistandard Sub-6 GHz Wireless Applications,” *Wirel. Commun. Mob. Comput.*, vol. 2022, 2022, <https://doi.org/10.1155/2022/4658082>.
- [26] S. Subramaniam, A. Sathish Kumar Selvaperumal, V. Jayapal, L. Subramaniam, and S. Kumar Selvaperumal, “High Gain Compact Multi-Band Microstrip Patch Antenna for 5g Network Wireless power transfer using conical and spiral coils View project 5G Mobile Antenna View project High Gain Compact Multi-Band Microstrip Patch Antenna for 5g Network,” *Int. J. Adv. Sci. Technol.*, vol. 29, no. 1, pp. 1390–1410, 2020, [Online]. Available: <https://www.researchgate.net/publication/339487905>
- [27] M. K. Shereen and M. I. Khattak, “A Hybrid Reconfigurability Structure for a Novel 5G Monopole Antenna for Future Mobile Communications at 28/38 GHz,” *Arab. J. Sci. Eng.*, vol. 47, no. 3, pp. 2745–2753, 2022, <https://doi.org/10.1007/s13369-021-05845-8>.
- [28] I. Serhsouh, M. Himdi, H. Lebbar, and H. Vettikalladi, “Reconfigurable SIW Antenna for Fixed Frequency Beam Scanning and 5G Applications,” *IEEE Access*, vol. 8, pp. 60084–60089, 2020, <https://doi.org/10.1109/ACCESS.2020.2983001>.
- [29] S. Ullah, I. Ahmad, Y. Raheem, S. Ullah, T. Ahmad, and U. Habib, “Hexagonal shaped CPW Feed based Frequency Reconfigurable Antenna for WLAN and Sub-6 GHz 5G applications,” *2020 Int. Conf. Emerg. Trends Smart Technol. ICETST 2020*, pp. 5–8, 2020, <https://doi.org/10.1109/ICETST49965.2020.9080688>.
- [30] B. Anantha, L. Merugu, and P. V.D. Somasekhar Rao, “A novel single feed frequency and polarization reconfigurable microstrip patch antenna,” *AEU - Int. J. Electron. Commun.*, vol. 72, pp. 8–16, 2017, <https://doi.org/10.1016/j.aeue.2016.11.012>.